

## Division of Air Quality Permit Application Submittal

Please find attached a permit application for :   
[Company Name; Facility Location]

- DAQ Facility ID (for existing facilities only):
- Current 45CSR13 and 45CSR30 (Title V) permits associated with this process (for existing facilities only):

- Type of NSR Application (check all that apply):
  - Construction
  - Modification
  - Class I Administrative Update
  - Class II Administrative Update
  - Relocation
  - Temporary
  - Permit Determination
- Type of 45CSR30 (TITLE V) Application:
  - Title V Initial
  - Title V Renewal
  - Administrative Amendment\*\*
  - Minor Modification\*\*
  - Significant Modification\*\*
  - Off Permit Change

**\*\*If the box above is checked, include the Title V revision information as ATTACHMENT S to the combined NSR/Title V application.**

- Payment Type:
  - Credit Card (Instructions to pay by credit card will be sent in the Application Status email.)
  - Check (Make checks payable to: WVDEP – Division of Air Quality)  
Mail checks to:  
WVDEP – DAQ – Permitting  
Attn: NSR Permitting Secretary  
601 57<sup>th</sup> Street, SE  
Charleston, WV 25304

**Please wait until DAQ emails you the Facility ID Number and Permit Application Number. Please add these identifiers to your check or cover letter with your check.**

- If the permit writer has any questions, please contact (all that apply):

- Responsible Official/Authorized Representative
  - Name:
  - Email:
  - Phone Number:
- Company Contact
  - Name:
  - Email:
  - Phone Number:
- Consultant
  - Name:
  - Email:
  - Phone Number:

**REGULATION 13 PERMIT APPLICATION  
FOR THE CONSTRUCTION OF AN  
AMMONIA PRODUCTION FACILITY IN  
MINGO COUNTY, WEST VIRGINIA**

**REDACTED VERSION**

*Prepared for:*

**TransGas Development Systems, LLC**  
630 First Avenue, Suite 30G  
New York, New York 10013-3799

*Prepared by:*

**Potesta & Associates, Inc.**  
7012 MacCorkle Avenue, SE  
Charleston, West Virginia 25304  
Phone: (304) 342-1400 Fax: (304) 343-9031  
Email: [potesta@potesta.com](mailto:potesta@potesta.com)

Project No. 0101-22-0132-001

June 30, 2023

**POTESTA**

# TABLE OF CONTENTS

Application for NSR Permit.....	SECTION I – III
Business Certificate .....	ATTACHMENT A
Site Location Map.....	ATTACHMENT B
Installation and Startup Schedule.....	ATTACHMENT C
Regulatory Discussion .....	ATTACHMENT D
Plot Plan.....	ATTACHMENT E
Process Flow Diagram(s).....	ATTACHMENT F
Process Description.....	ATTACHMENT G
Material Safety Data Sheets.....	ATTACHMENT H
Emissions Units Table .....	ATTACHMENT I
Emission Points Data Summary Sheet.....	ATTACHMENT J
Fugitive Emissions Data Summary Sheet.....	ATTACHMENT K
Emissions Unit Data Sheet(s) .....	ATTACHMENT L
Air Pollution Control Device(s).....	ATTACHMENT M
Supporting Emissions Calculations .....	ATTACHMENT N
Monitoring/Recordkeeping/Reporting/Testing Plans .....	ATTACHMENT O
Public Notice.....	ATTACHMENT P
Business Confidential Claims .....	ATTACHMENT Q
Confidential Haldor Topsoe Documents .....	APPENDIX 1
Startup and Emergency Generator Information.....	APPENDIX 2
Detailed Process Flow Diagrams .....	APPENDIX 3

Attachments not applicable to this submission: Attachment R, Authority Forms and Attachment S, Title V Permit Revision Information.

**SECTION I - III**

**APPLICATION FOR NSR PERMIT**



WEST VIRGINIA DEPARTMENT OF ENVIRONMENTAL PROTECTION  
**DIVISION OF AIR QUALITY**

601 57<sup>th</sup> Street, SE  
Charleston, WV 25304  
(304) 926-0475  
[www.dep.wv.gov/daq](http://www.dep.wv.gov/daq)

**APPLICATION FOR NSR PERMIT  
AND  
TITLE V PERMIT REVISION  
(OPTIONAL)**

PLEASE CHECK ALL THAT APPLY TO **NSR (45CSR13)** (IF KNOWN):

- CONSTRUCTION**     **MODIFICATION**     **RELOCATION**  
 **CLASS I ADMINISTRATIVE UPDATE**     **TEMPORARY**  
 **CLASS II ADMINISTRATIVE UPDATE**     **AFTER-THE-FACT**

PLEASE CHECK TYPE OF **45CSR30 (TITLE V)** REVISION (IF ANY):

- ADMINISTRATIVE AMENDMENT**     **MINOR MODIFICATION**  
 **SIGNIFICANT MODIFICATION**

IF ANY BOX ABOVE IS CHECKED, INCLUDE TITLE V REVISION INFORMATION AS **ATTACHMENT S** TO THIS APPLICATION

**FOR TITLE V FACILITIES ONLY:** Please refer to "Title V Revision Guidance" in order to determine your Title V Revision options (Appendix A, "Title V Permit Revision Flowchart") and ability to operate with the changes requested in this Permit Application.

**Section I. General**

1. Name of applicant (as registered with the WV Secretary of State's Office): TransGas Development Systems, LLC		2. Federal Employer ID No. (FEIN): 20343110	
3. Name of facility (if different from above): Ammonia Production Facility		4. The applicant is the: <input type="checkbox"/> OWNER <input type="checkbox"/> OPERATOR <input checked="" type="checkbox"/> BOTH	
5A. Applicant's mailing address: 630 First Avenue, Suite 30G New York, New York 10016-3799		5B. Facility's present physical address: Right Fork Bens Creek Road Wharnccliffe, WV	
6. <b>West Virginia Business Registration.</b> Is the applicant a resident of the State of West Virginia? <input checked="" type="checkbox"/> <b>YES</b> <input type="checkbox"/> <b>NO</b> ⇨ If <b>YES</b> , provide a copy of the <b>Certificate of Incorporation/Organization/Limited Partnership</b> (one page) including any name change amendments or other Business Registration Certificate as <b>Attachment A</b> . ⇨ If <b>NO</b> , provide a copy of the <b>Certificate of Authority/Authority of L.L.C./Registration</b> (one page) including any name change amendments or other Business Certificate as <b>Attachment A</b> .			
7. If applicant is a subsidiary corporation, please provide the name of parent corporation: No			
8. Does the applicant own, lease, have an option to buy or otherwise have control of the <i>proposed site</i> ? <input type="checkbox"/> <b>YES</b> <input type="checkbox"/> <b>NO</b> ⇨ If <b>YES</b> , please explain:    Applicant has an option on the site with the Mingo County Development Authority. ⇨ If <b>NO</b> , you are not eligible for a permit for this source.			
9. Type of plant or facility (stationary source) to be <b>constructed, modified, relocated, administratively updated</b> or <b>temporarily permitted</b> (e.g., coal preparation plant, primary crusher, etc.): Ammonia Production Facility		10. North American Industry Classification System (NAICS) code for the facility: 325311	
11A. DAQ Plant ID No. (for existing facilities only): 059-00102		11B. List all current 45CSR13 and 45CSR30 (Title V) permit numbers associated with this process (for existing facilities only): R13-2791A	

**All of the required forms and additional information can be found under the Permitting Section of DAQ's website, or requested by phone.**



24. Provide **Material Safety Data Sheets (MSDS)** for all materials processed, used or produced as **Attachment H**.  
 ⇨ For chemical processes, provide a MSDS for each compound emitted to the air.

25. Fill out the **Emission Units Table** and provide it as **Attachment I**.

26. Fill out the **Emission Points Data Summary Sheet (Table 1 and Table 2)** and provide it as **Attachment J**.

27. Fill out the **Fugitive Emissions Data Summary Sheet** and provide it as **Attachment K**.

28. Check all applicable **Emissions Unit Data Sheets** listed below:

<input type="checkbox"/> Bulk Liquid Transfer Operations	<input type="checkbox"/> Haul Road Emissions	<input type="checkbox"/> Quarry
<input type="checkbox"/> Chemical Processes	<input type="checkbox"/> Hot Mix Asphalt Plant	<input type="checkbox"/> Solid Materials Sizing, Handling and Storage Facilities
<input type="checkbox"/> Concrete Batch Plant	<input type="checkbox"/> Incinerator	<input checked="" type="checkbox"/> Storage Tanks
<input type="checkbox"/> Grey Iron and Steel Foundry	<input checked="" type="checkbox"/> Indirect Heat Exchanger	

General Emission Unit, specify Feed Purification, Reformer Sections, ATR Section, CO Conversion Section, Nitrogen Wash Unit, Ammonia Loop Unit, CO2 Removal Section.

Fill out and provide the **Emissions Unit Data Sheet(s)** as **Attachment L**.

29. Check all applicable **Air Pollution Control Device Sheets** listed below:

<input type="checkbox"/> Absorption Systems	<input type="checkbox"/> Baghouse	<input checked="" type="checkbox"/> Flare
<input type="checkbox"/> Adsorption Systems	<input type="checkbox"/> Condenser	<input type="checkbox"/> Mechanical Collector
<input type="checkbox"/> Afterburner	<input type="checkbox"/> Electrostatic Precipitator	<input type="checkbox"/> Wet Collecting System

Other Collectors, specify SCR System

Fill out and provide the **Air Pollution Control Device Sheet(s)** as **Attachment M**.

30. Provide all **Supporting Emissions Calculations** as **Attachment N**, or attach the calculations directly to the forms listed in Items 28 through 31.

31. **Monitoring, Recordkeeping, Reporting and Testing Plans.** Attach proposed monitoring, recordkeeping, reporting and testing plans in order to demonstrate compliance with the proposed emissions limits and operating parameters in this permit application. Provide this information as **Attachment O**.

➤ Please be aware that all permits must be practically enforceable whether or not the applicant chooses to propose such measures. Additionally, the DAQ may not be able to accept all measures proposed by the applicant. If none of these plans are proposed by the applicant, DAQ will develop such plans and include them in the permit.

32. **Public Notice.** At the time that the application is submitted, place a **Class I Legal Advertisement** in a newspaper of general circulation in the area where the source is or will be located (See 45CSR§13-8.3 through 45CSR§13-8.5 and **Example Legal Advertisement** for details). Please submit the **Affidavit of Publication** as **Attachment P** immediately upon receipt.

33. **Business Confidentiality Claims.** Does this application include confidential information (per 45CSR31)?

YES       NO

➤ If **YES**, identify each segment of information on each page that is submitted as confidential and provide justification for each segment claimed confidential, including the criteria under 45CSR§31-4.1, and in accordance with the DAQ's "**Precautionary Notice – Claims of Confidentiality**" guidance found in the **General Instructions** as **Attachment Q**.

### Section III. Certification of Information

34. **Authority/Delegation of Authority.** Only required when someone other than the responsible official signs the application. Check applicable **Authority Form** below: Not Required

<input type="checkbox"/> Authority of Corporation or Other Business Entity	<input type="checkbox"/> Authority of Partnership
<input type="checkbox"/> Authority of Governmental Agency	<input type="checkbox"/> Authority of Limited Partnership

Submit completed and signed **Authority Form** as **Attachment R**.

*All of the required forms and additional information can be found under the Permitting Section of DAQ's website, or requested by phone.*

35A. **Certification of Information.** To certify this permit application, a Responsible Official (per 45CSR§13-2.22 and 45CSR§30-2.28) or Authorized Representative shall check the appropriate box and sign below.

**Certification of Truth, Accuracy, and Completeness**

I, the undersigned  **Responsible Official** /  **Authorized Representative**, hereby certify that all information contained in this application and any supporting documents appended hereto, is true, accurate, and complete based on information and belief after reasonable inquiry I further agree to assume responsibility for the construction, modification and/or relocation and operation of the stationary source described herein in accordance with this application and any amendments thereto, as well as the Department of Environmental Protection, Division of Air Quality permit issued in accordance with this application, along with all applicable rules and regulations of the West Virginia Division of Air Quality and W.Va. Code § 22-5-1 et seq. (State Air Pollution Control Act). If the business or agency changes its Responsible Official or Authorized Representative, the Director of the Division of Air Quality will be notified in writing within 30 days of the official change.

**Compliance Certification**

Except for requirements identified in the Title V Application for which compliance is not achieved, I, the undersigned hereby certify that, based on information and belief formed after reasonable inquiry, all air contaminant sources identified in this application are in compliance with all applicable requirements.

SIGNATURE \_\_\_\_\_

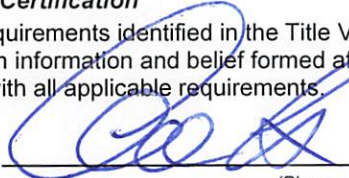

(Please use blue ink)

DATE: \_\_\_\_\_

6/30/23

(Please use blue ink)

35B. Printed name of signee: Adam Victor

35C. Title: President

35D. E-mail: adam@tgds.com

36E. Phone: (212) 828-0001

36F. FAX: Use Email

36A. Printed name of contact person (if different from above): Same as above

36B. Title:

36C. E-mail:

36D. Phone:

36E. FAX:

**PLEASE CHECK ALL APPLICABLE ATTACHMENTS INCLUDED WITH THIS PERMIT APPLICATION:**

- |  |  |
|--|--|
| <input checked="" type="checkbox"/> Attachment A: Business Certificate               | <input checked="" type="checkbox"/> Attachment K: Fugitive Emissions Data Summary Sheet            |
| <input checked="" type="checkbox"/> Attachment B: Map(s)                             | <input checked="" type="checkbox"/> Attachment L: Emissions Unit Data Sheet(s)                     |
| <input checked="" type="checkbox"/> Attachment C: Installation and Start Up Schedule | <input checked="" type="checkbox"/> Attachment M: Air Pollution Control Device Sheet(s)            |
| <input checked="" type="checkbox"/> Attachment D: Regulatory Discussion              | <input checked="" type="checkbox"/> Attachment N: Supporting Emissions Calculations                |
| <input checked="" type="checkbox"/> Attachment E: Plot Plan                          | <input checked="" type="checkbox"/> Attachment O: Monitoring/Recordkeeping/Reporting/Testing Plans |
| <input checked="" type="checkbox"/> Attachment F: Detailed Process Flow Diagram(s)   | <input checked="" type="checkbox"/> Attachment P: Public Notice                                    |
| <input checked="" type="checkbox"/> Attachment G: Process Description                | <input checked="" type="checkbox"/> Attachment Q: Business Confidential Claims                     |
| <input checked="" type="checkbox"/> Attachment H: Material Safety Data Sheets (MSDS) | <input type="checkbox"/> Attachment R: Authority Forms   |
| <input checked="" type="checkbox"/> Attachment I: Emission Units Table               | <input type="checkbox"/> Attachment S: Title V Permit Revision Information                         |
| <input checked="" type="checkbox"/> Attachment J: Emission Points Data Summary Sheet | <input checked="" type="checkbox"/> Application Fee  |

*Please mail an original and three (3) copies of the complete permit application with the signature(s) to the DAQ, Permitting Section, at the address listed on the first page of this application. Please DO NOT fax permit applications.*

**FOR AGENCY USE ONLY – IF THIS IS A TITLE V SOURCE:**

- Forward 1 copy of the application to the Title V Permitting Group and:
- For Title V Administrative Amendments:
  - NSR permit writer should notify Title V permit writer of draft permit,
- For Title V Minor Modifications:
  - Title V permit writer should send appropriate notification to EPA and affected states within 5 days of receipt,
  - NSR permit writer should notify Title V permit writer of draft permit.
- For Title V Significant Modifications processed in parallel with NSR Permit revision:
  - NSR permit writer should notify a Title V permit writer of draft permit,
  - Public notice should reference both 45CSR13 and Title V permits,
  - EPA has 45 day review period of a draft permit.

*All of the required forms and additional information can be found under the Permitting Section of DAQ's website, or requested by phone.*



**ATTACHMENT A**  
**BUSINESS CERTIFICATE**

**WEST VIRGINIA  
STATE TAX DEPARTMENT  
BUSINESS REGISTRATION  
CERTIFICATE**

ISSUED TO:  
**TRANSGAS DEVELOPMENT SYSTEMS, LLC  
630 1ST AVE APT 30G  
NEW YORK, NY 10016-3799**

**BUSINESS REGISTRATION ACCOUNT NUMBER: 2218-0756**

This certificate is issued on: 06/29/2010

*This certificate is issued by  
the West Virginia State Tax Commissioner  
in accordance with W.Va. Code § 11-12.*

*The person or organization identified on this certificate is registered  
to conduct business in the State of West Virginia at the location above.*

This certificate is not transferrable and must be displayed at the location for which issued.

This certificate shall be permanent until cessation of the business for which the certificate of registration was granted or until it is suspended, revoked or cancelled by the Tax Commissioner.

Change in name or change of location shall be considered a cessation of the business and a new certificate shall be required.

**TRAVELING/STREET VENDORS:** Must carry a copy of this certificate in every vehicle operated by them.  
**CONTRACTORS, DRILLING OPERATORS, TIMBER/LOGGING OPERATIONS:** Must have a copy of this certificate displayed at every job site within West Virginia.

**ATTACHMENT B**  
**SITE LOCATION MAP**

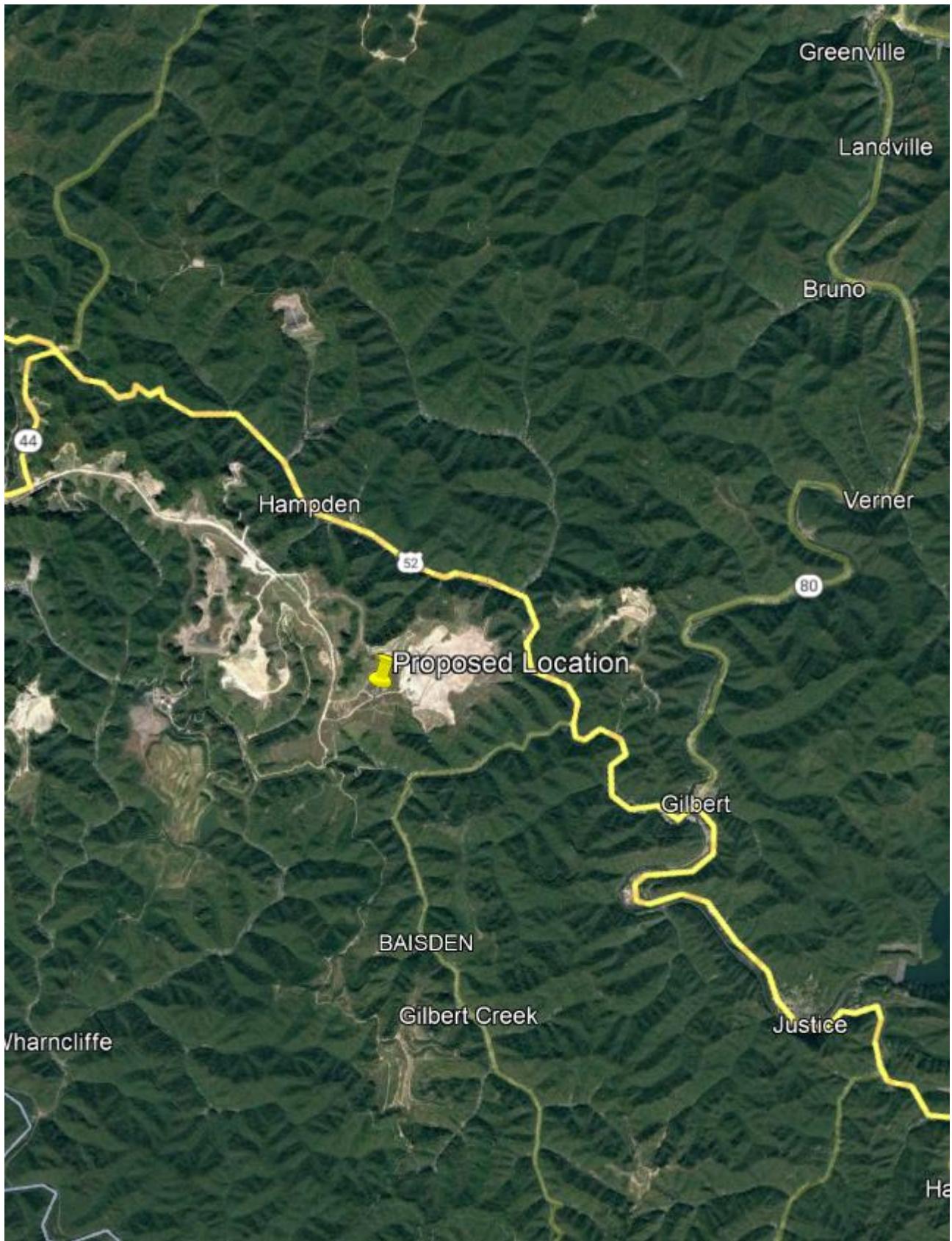

**Potesta & Associates, Inc.**

7012 MacCorkle Avenue, SE, Charleston, WV 25304  
Phone: (304) 342-1400 Fax: (304) 343-9031  
E-Mail: potesta@potesta.com

**TransGas Development Systems, LLC**

**Ammonia Production Facility**

Wharncliffe, West Virginia  
Project No. 0101-22-0132-001

# **ATTACHMENT C**

## **INSTALLATION AND STARTUP SCHEDULE**

## **ATTACHMENT C**

### **INSTALLATION AND START UP SCHEDULE**

Construction of the facility will begin after receipt of Construction Permit from West Virginia Department of Environmental Protection, Division of Air Quality, and other necessary regulatory approvals on or near January 1, 2024. Operations will commence approximately 12 months after the beginning of construction.

**ATTACHMENT D**

**REGULATORY DISCUSSION**

# ATTACHMENT D

## REGULATORY DISCUSSION

The facility proposed herein, or portions of the facility, may be subject to the following regulations based on a review of potential air quality regulations:

1. State Regulations
  - A. 45CSR2 – “To Prevent and Control Particulate Air Pollution from Combustion of Fuel in Indirect Heat Exchangers”
  - B. 45CSR2A – “Testing, Monitoring, Recordkeeping and Reporting Requirements Under 45CSR2”
  - C. 45CSR4 – “To Prevent and Control the Discharge of Air Pollutants into the Open Air Which Causes or Contributes to an Objectionable Odor or Odors”
  - D. 45CSR7 – “To Prevent and Control Particulate Matter Air Pollution from Manufacturing Processes and Associated Operations”
  - E. 45CSR7A – “Compliance Test Procedures for 45CSR7 – To Prevent and Control Particulate Matter Air Pollution from Manufacturing Process Operations”  
Provides guidance for complying with the requirements of 45CSR7.
  - F. 45CSR10 – “To Prevent and Control Air Pollution from the Emission of Sulfur Oxides”
  - G. 45CSR10A – “Testing, Monitoring, Recordkeeping and Reporting Requirements Under 45CSR10”
  - H. 45CSR13 – “Permits for Construction, Modification, Relocation and Operation of Stationary Sources of Air Pollutants, Notification Requirements, Temporary Permits, General Permits, and Procedures for Evaluation”
  - I. 45CSR16 – “Standards of Performance for New Stationary Sources”
  - J. 45CSR20 – “Good Engineering Practice as Applies to Stack Heights”
  - K. 45SCR30 – “Requirements for Operation Permits”
  - L. 45CSR31 – “Confidential Information”

This application contains confidential information. This claim of confidentiality is made in accordance with the requirements of 45CSR31.



2. Federal Regulations

- A. 40CFR60 Subpart A – General Provisions
- B. 40CFR60 Subpart Dc - Standards of Performance for Small Industrial-Commercial-Institutional Steam Generating Units
- C. 40CFR60 Subpart JJJ - Standard of Performance for Stationary Spark Ignition Internal Combustion Engines
- D. 40CFR60 – Standards of Performance for New Stationary Sources Subpart A – General Provisions Part 60.18-General Control Device Requirements.

# **ATTACHMENT E**

## **PLOT PLANS**

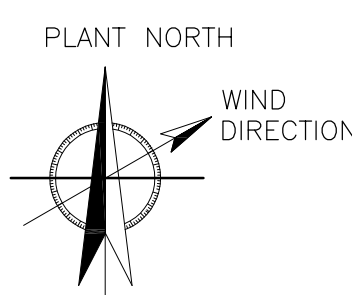

CO2 CONVERSION SECTION (7S) VENT TO PROCESS GAS VENT FLARE

REFORMING SECTION (2S) VENT TO PROCESS GAS VENT FLARE  
CO CONVERSION SECTION (4S) VENT TO FLARE

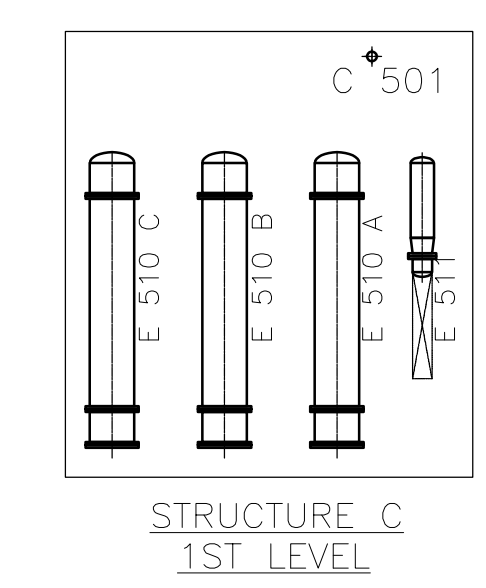
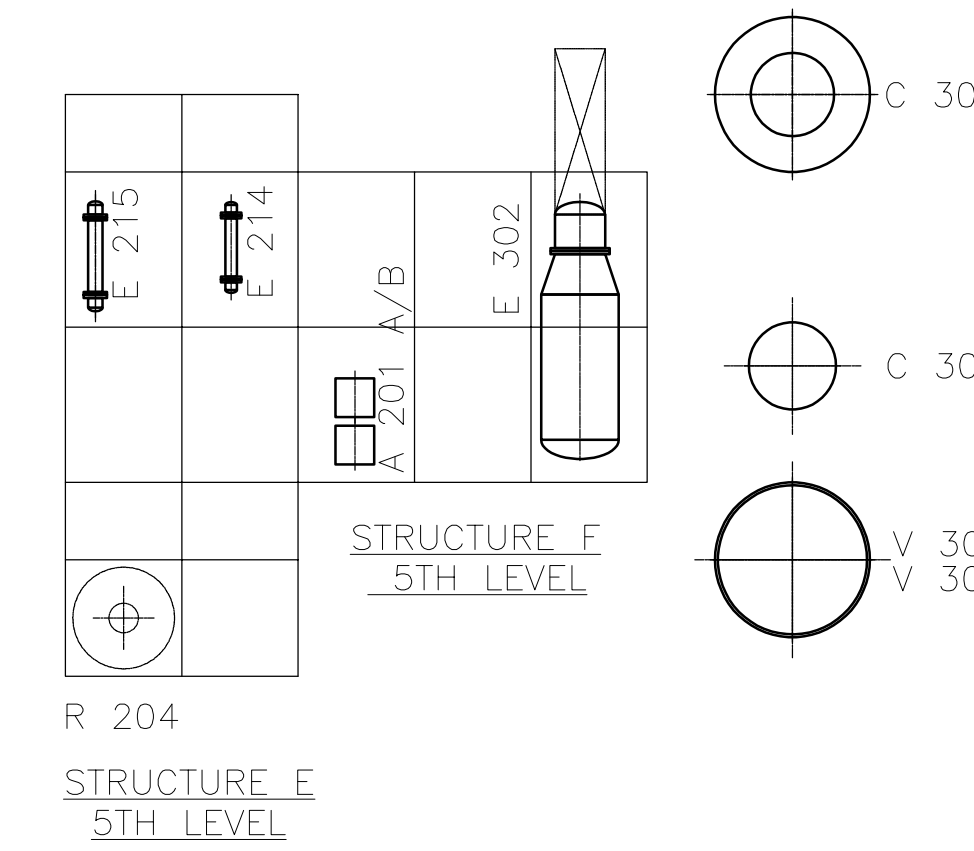
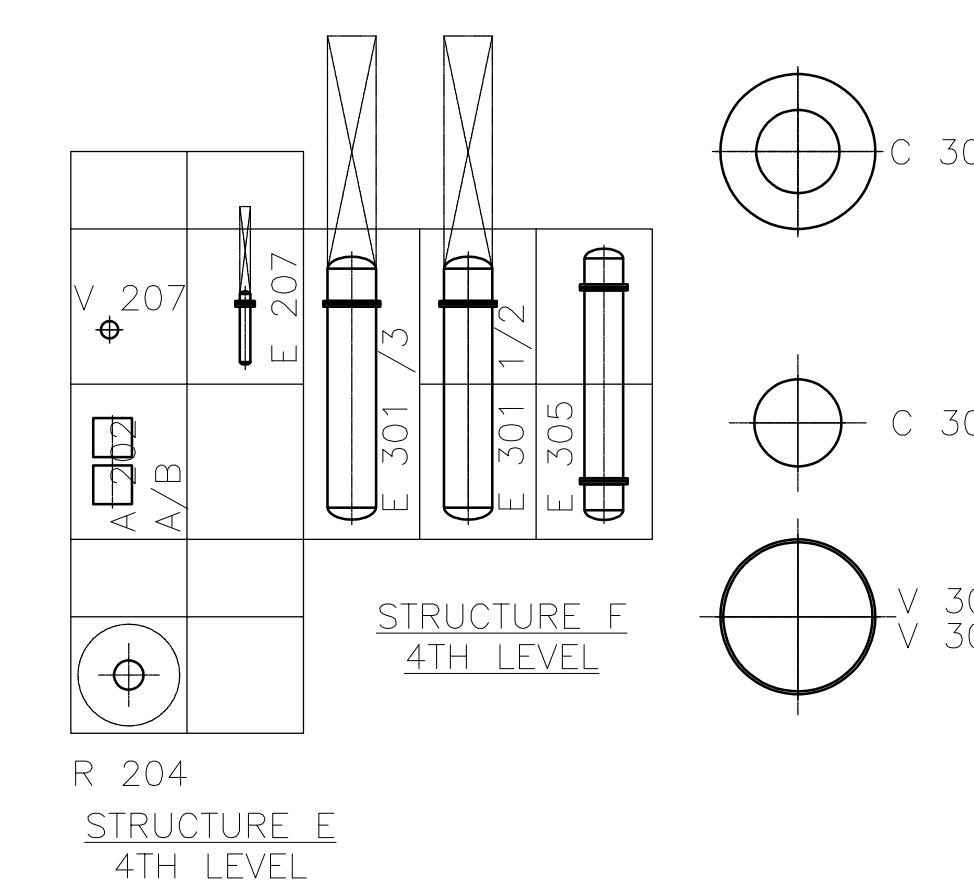
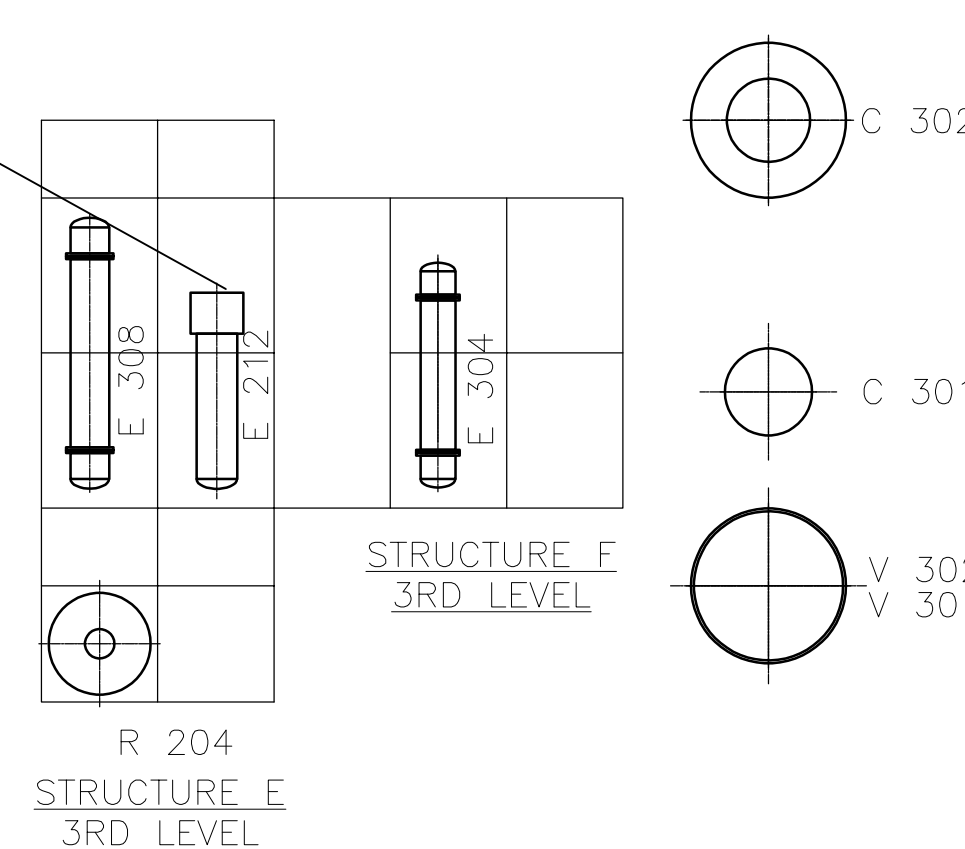
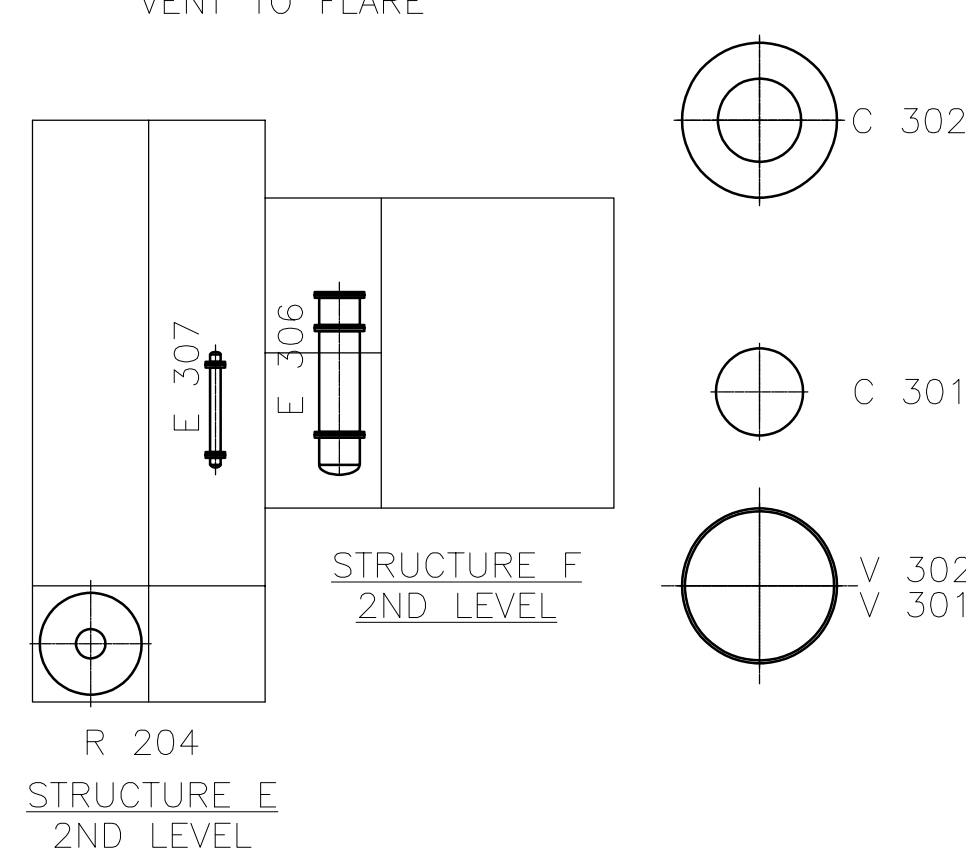
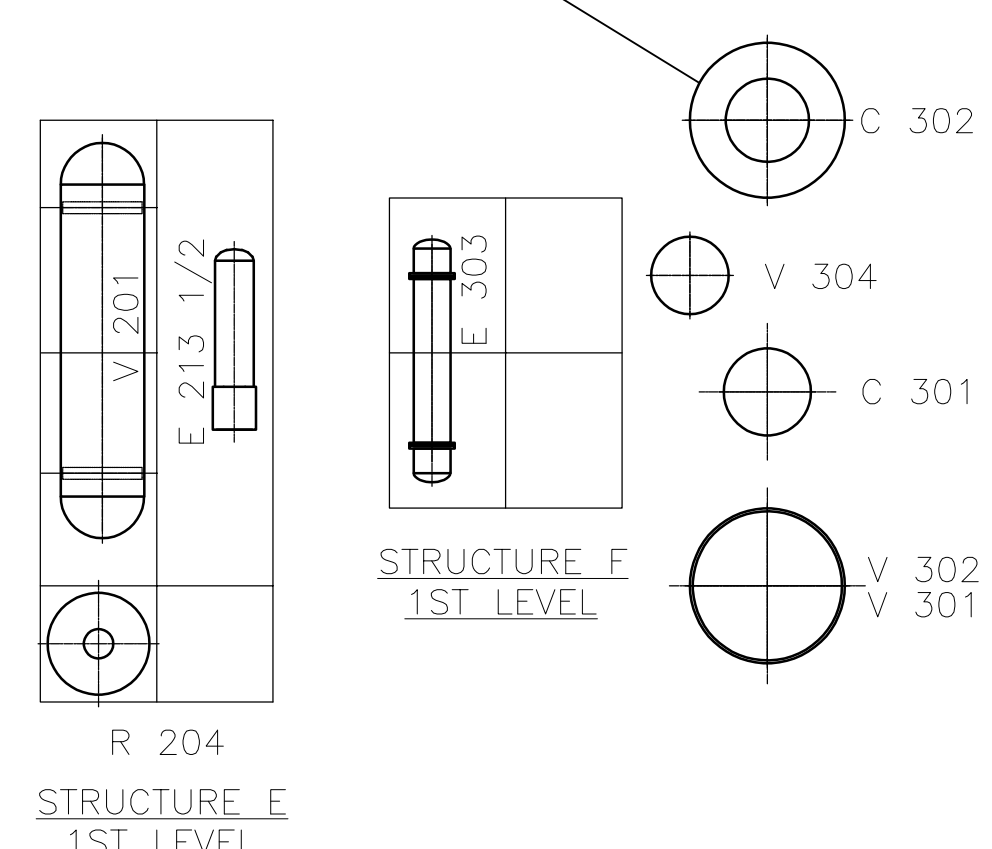

NOTES:  
1. CONCEPTUAL LAYOUT IS BASED ON PRELIMINARY INFORMATION PROVIDED BY VENDORS.  
2. THIS DRAWING IS TYPICAL LAYOUT FOR 1 UNIT. AIR SEPARATION UNIT AND FLARE CAN MOVE AS REQUIRED TO FIT ON PROPERTY.

This plot plan shows one (1) ammonia unit. There are six (6) proposed ammonia units that make up the entire facility. The source identifications, control, and emission points are labeled to show the locations. For each ammonia unit, the identifying numbers will be followed with a -1, -2, etc. to designate the ammonia which they are associated with.

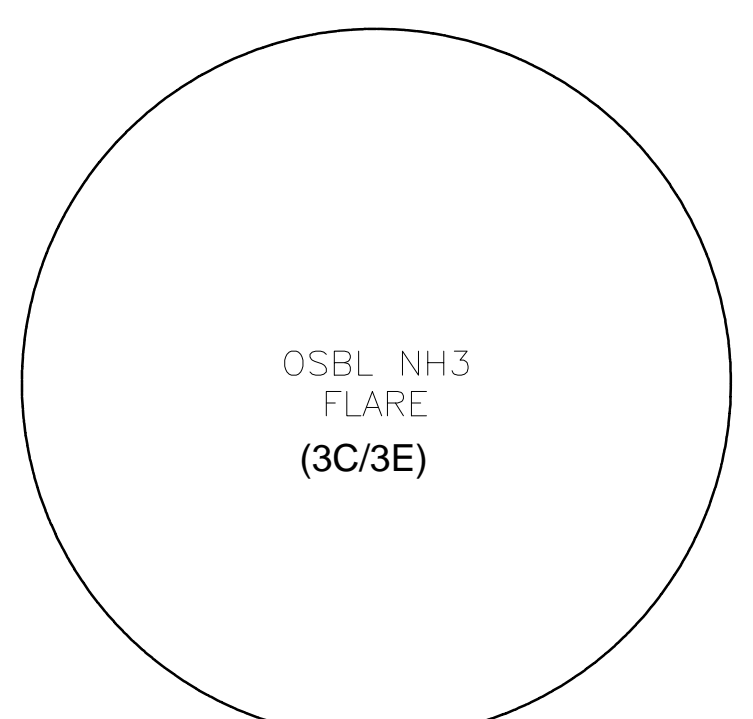
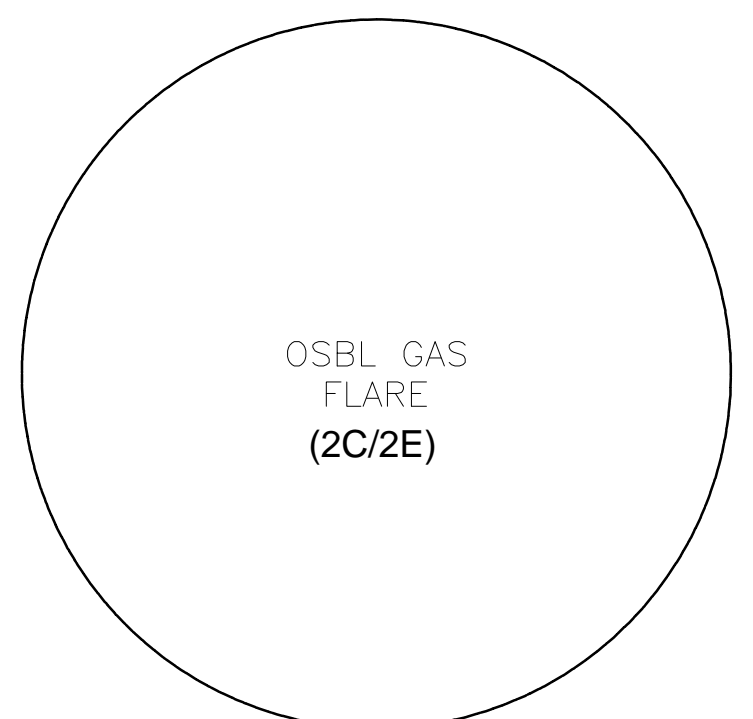
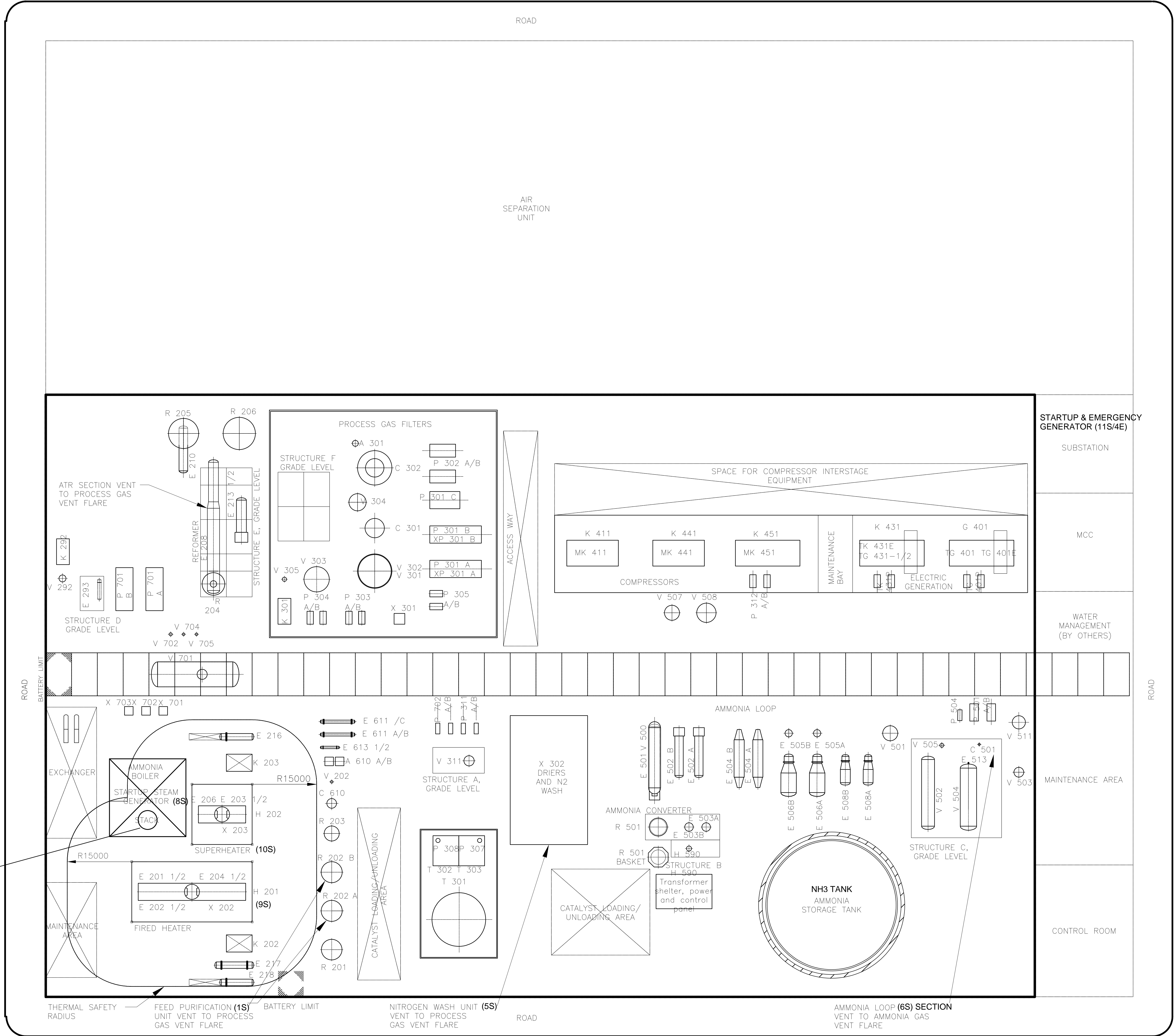

**ISSUED FOR PERMITTING AND PLANNING**  
**6/28/23**

- NOTES**
- ALL DIMENSIONS ARE IN MM.
  - ALL EQUIPMENT & STRUCTURE SIZES AND LOCATIONS ARE PRELIMINARY AND SUBJECT TO CHANGES IN FURTHER ENGINEERING DESIGN PHASES.
  - PLANT NORTH & PREVAILING WIND DIRECTION ARE MARKED ON ASSUMPTION BASIS.
  - CARBON CAPTURE UNIT (X 200) IS NOT SHOWN IN THIS PLOT AND SHALL BE INCLUDED IN FURTHER ENGINEERING DESIGN PHASES.



Information contained herein is confidential. It may not be used for any purpose other than for which it has been issued, and may not be used by or disclosed to third parties without written approval of Haldor Topsoe A/S.

REV.	DESCRIPTION	DATE	DRAWN	CHKD.	APPR.
0	First issue	May 30, 2023	HU/GRAY	-	CSVI

TRANSGAS DEVELOPMENT SYSTEMS, LLC  
MINGO COUNTY, WEST VIRGINIA

SCALE: 1 : 350

DOCUMENT ID: \_\_\_\_\_

JOB NO. \_\_\_\_\_ DOCUMENT NUMBER \_\_\_\_\_

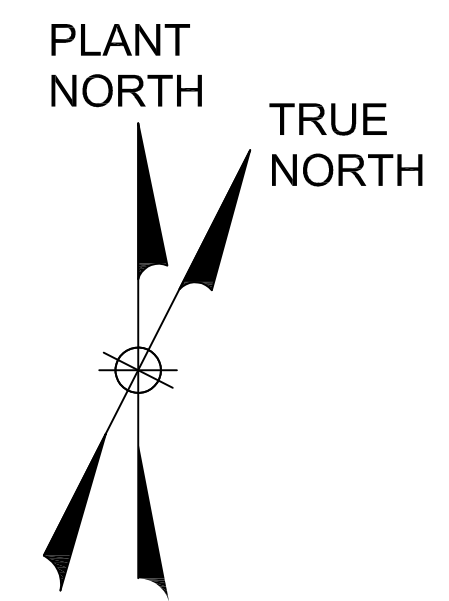
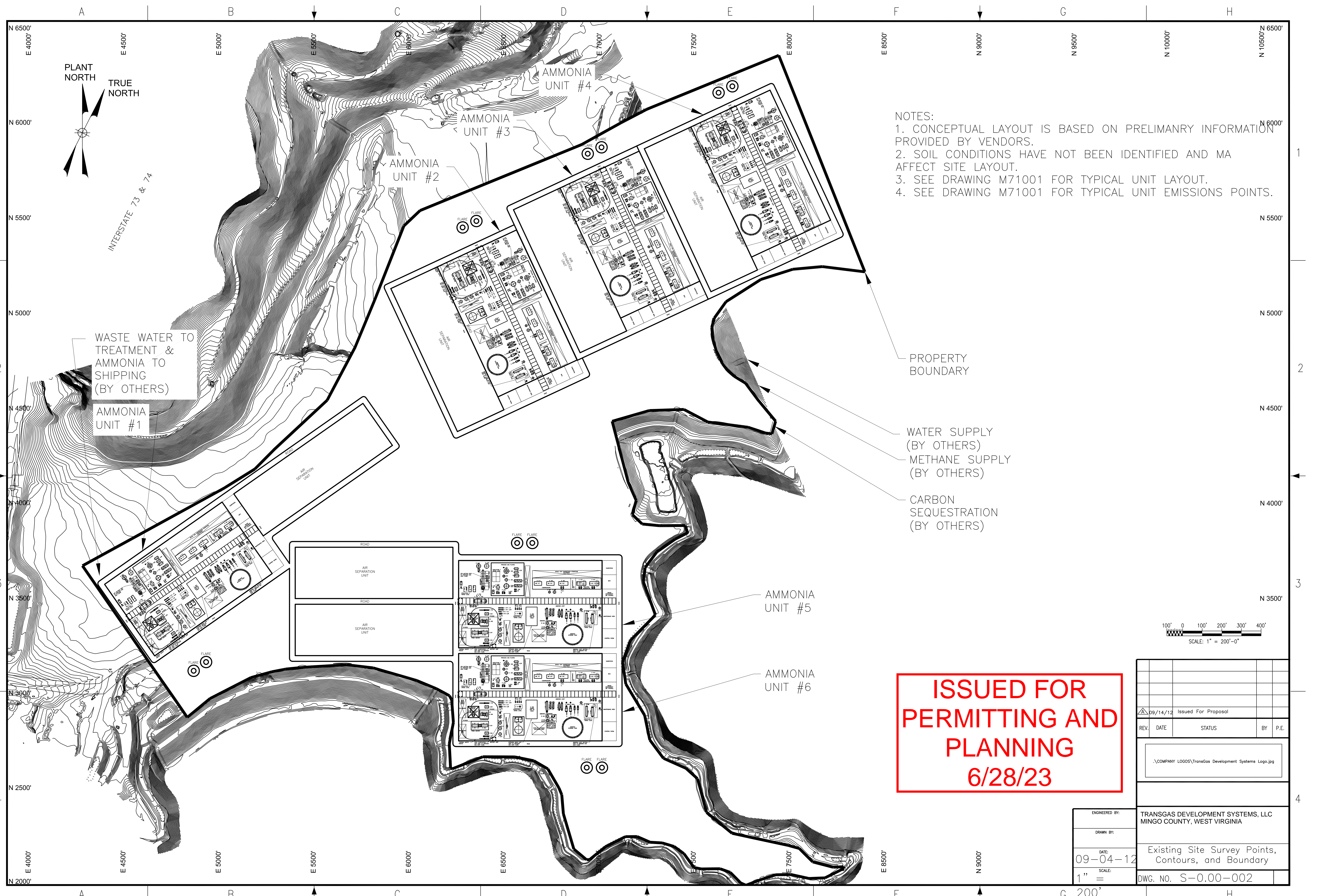

- NOTES:
1. CONCEPTUAL LAYOUT IS BASED ON PRELIMINARY INFORMATION PROVIDED BY VENDORS.
  2. SOIL CONDITIONS HAVE NOT BEEN IDENTIFIED AND MAY AFFECT SITE LAYOUT.
  3. SEE DRAWING M71001 FOR TYPICAL UNIT LAYOUT.
  4. SEE DRAWING M71001 FOR TYPICAL UNIT EMISSIONS POINTS.

PROPERTY BOUNDARY

WATER SUPPLY (BY OTHERS)  
METHANE SUPPLY (BY OTHERS)

CARBON SEQUESTRATION (BY OTHERS)

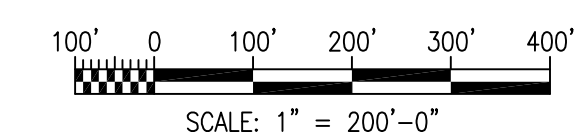

**ISSUED FOR PERMITTING AND PLANNING 6/28/23**

REV.	DATE	STATUS	BY	P.E.
09/14/12		Issued For Proposal		

COMPANY LOGOS\TransGas Development Systems Logo.jpg

ENGINEERED BY:	TRANSGAS DEVELOPMENT SYSTEMS, LLC
DRAWN BY:	MINGO COUNTY, WEST VIRGINIA
DATE:	Existing Site Survey Points, Contours, and Boundary
SCALE:	DWG. NO. S-0.00-002
09-04-12	
1" = 200'	

**ATTACHMENT F**  
**PROCESS FLOW DIAGRAM(S)**

# Block Flow Diagram

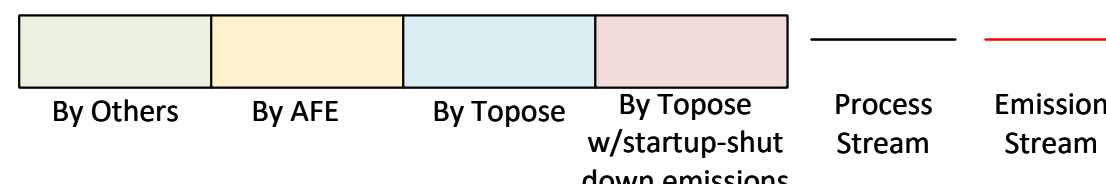
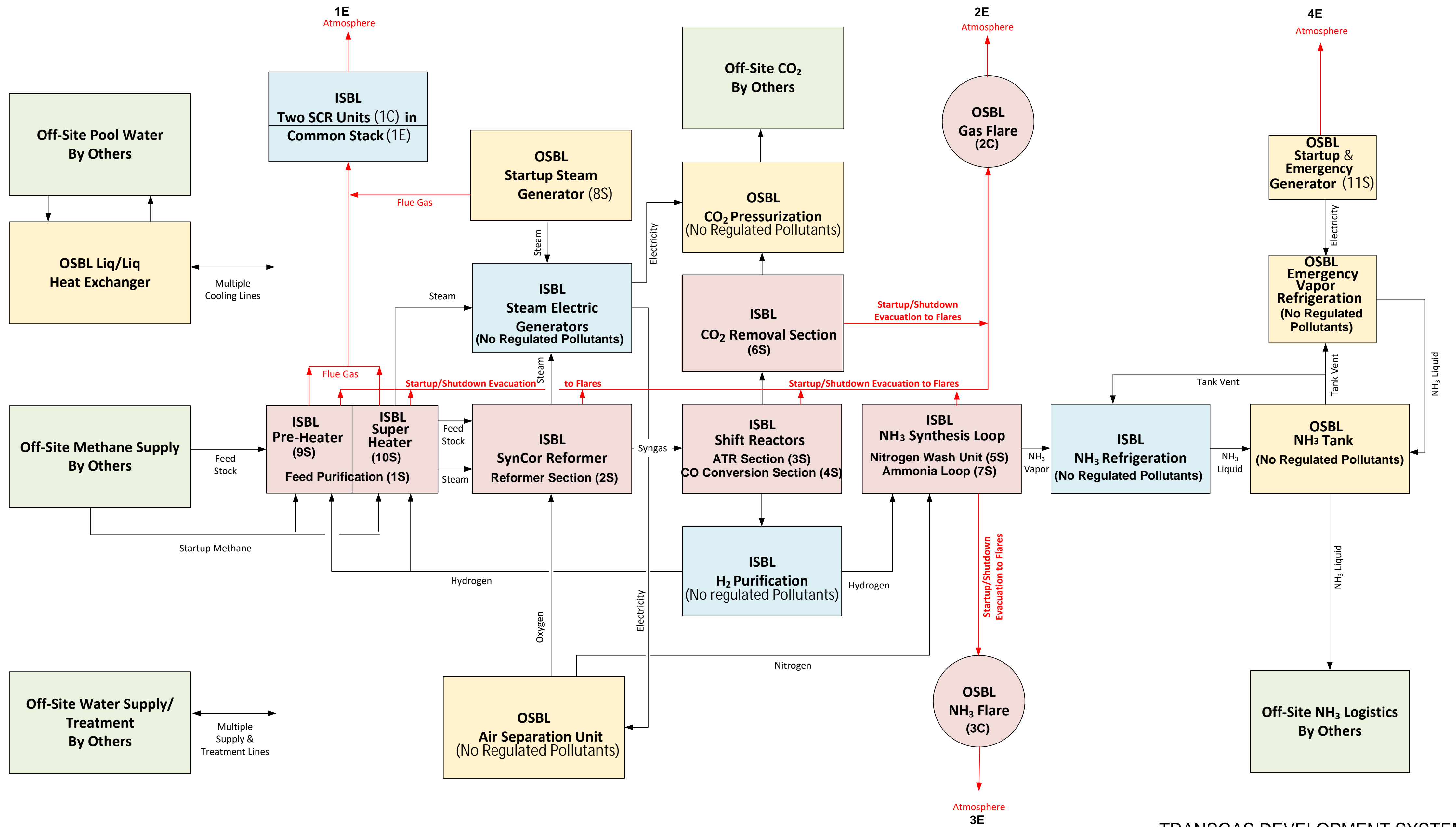

**ATTACHMENT G**

**PROCESS DESCRIPTION**

# ATTACHMENT G

## PROCESS DESCRIPTION

### Overview

The block flow diagram presents the order of the units throughout the process of ammonia production. This description provides a discussion on the process in detail. Ammonia (NH<sub>3</sub>) is one of the most widely produced chemicals in the world. Ammonia is considered as the only carbon-free hydrogen storage compound that can overarch water, energy, and food value chains, while allowing long- and short-term energy storage at lower costs than that of pure hydrogen. Ammonia Haber-Bosch (HB) synthesis is undoubtedly one of the most important chemical breakthroughs in history with current production of NH<sub>3</sub> in excess of 180 million tons per year. Currently, more than 80% of the produced ammonia is used for fertilizers, helping to feed over 70% of the world population. As a result, nearly 50% of the nitrogen found in the human body has passed through the HB process. Ammonia also has promising potential as an energy carrier.

Following the HB process, ammonia is produced from a mixture of hydrogen (H<sub>2</sub>) and nitrogen (N<sub>2</sub>), where the molar ratio of N<sub>2</sub> to H<sub>2</sub> is approximately 3:1. Besides these two components, trace amounts of inert gases-such as argon (Ar), methane (CH<sub>4</sub>), and hydrogen (H<sub>2</sub>) in the syngas contribute those to the product.

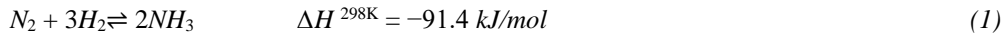
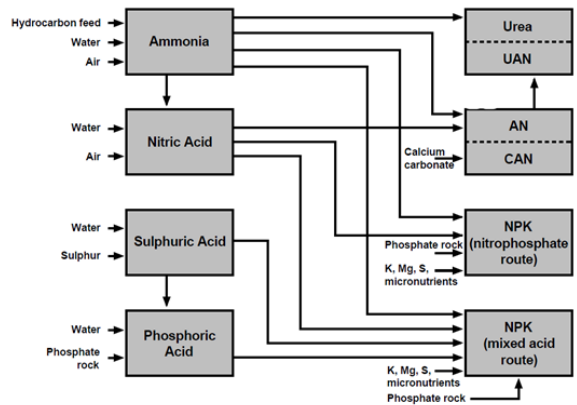

Figure 1 shows how ammonia can be used as a liquid, anhydrous ammonia (AN), or converted into one of several other products with addition of various acids: Nitric Acid, Sulfuric Acid or Phosphoric Acid. Products include Anhydrous Ammonia (AN) Urea and Urea Ammonium Nitrate (UAN), Ammonium Nitrate (AN) or Calcium Ammonium Nitrate (CAN).

The main production processes for ammonia synthesis gas currently in operation are:

- Steam reforming of natural gas (SMR) or other light hydrocarbons (Natural Gas Liquids, Liquefied Petroleum Gas, Naphtha),
- Partial oxidation of coal, heavy fuel oil or vacuum residue, and
- Auto thermal reforming of methane.

Currently, the vast majority of large-scale ammonia synthesis plants are coupled to SMR.



### TECHNOLOGY SELECTION

For more than 60 years, Topsoe has been one of the main suppliers of catalysts and technology for the ammonia industry. By the introduction of new catalysts, new equipment design, and extensive process optimization studies, Topsoe has contributed significantly to the development of efficient ammonia production technology. Today, approximately 50% of new ammonia plants use Topsoe technology.

**5,200 MTPD Ammonia Plant**

**Figure 1 – Ammonia based products**

Key Performance Measures		Syngas Technology	
		SMR	ATR
Total NG Process + Fuel	SF1/MT NH3 (1020 BTU/SF1 <sup>1</sup> )	33,333	26,569
	nM <sup>2</sup> /MT NH3 (9072 kcal/nM <sup>2</sup> )	850	752
Net Power Input <sup>2</sup>	kWh/MT NH3	30	11
	NG Equivalent (HHV @35% efficiency)	2,941	98
Total Eq. NG Prower Basis	SF1 <sup>1</sup> /MT NH3 (1020 BTU/SF1 <sup>1</sup> )	83	3
	nM <sup>2</sup> /MT NH3 (9072 kcal/nM <sup>2</sup> )	36,275	26,667
	SF1 <sup>1</sup> /MT NH3 (1020 BTU/SF1 <sup>1</sup> )	933	755
	Relative	100%	81%
O <sub>2</sub> consumption	MT O <sub>2</sub> per MT NH3	0	0.64
Steam to Carbon Ratio	Moles	3	0.6
CH <sub>4</sub> in raw syngas	Mole % Dry	4.3%	1.0%
CO/CO <sub>2</sub> ratio in raw syngas	Moles	2.3	6.5
Water in crude NH3	wt. %	17	5
<b>CAPEX/TPC:</b>			
Total Plant Cost, USGC <sup>1</sup>	US\$ million	1,200	650-900
TPC Savings: ASU moved OTF	US\$ million	0	98
Total Project Cost, USGC, w/o ASU	US\$ million	1,200	552-802
	Relative	100%	46-67%
<b>OPEX:</b>			
NG and Oxygen OTF	US\$ / MT NH3	129.5	125.98
Fixed O&M (including land lease) <sup>3</sup>	US\$ / MT NH3	35.01	30.44
Total	US\$ / MT NH3	164.51	156.42
	Relative	100%	95%

<sup>1</sup> w/o land, tanks & dock ~150 million  
<sup>2</sup> ATR ASU is fully integrated steam driven  
<sup>3</sup> Fixed O&M ATR=100%, SMR=115%, SMR/ATR=110%

Figure 2 – Technology selection matrix



As with the methanol technology selection a matrix (Figure 2) comparing the technologies and providers was completed. The results indicate that an ATR-based ammonia process has a lower Capex and Opex.

There are several vendors of ammonia technology (Figure 3). However, only Topsoe has completed ATR plants. Topsoe pioneered advanced autothermal reforming throughout the 1990s and commercialized the low steam-to-carbon (S/C) ATR technology in 2002.

Technology Provider		Topsoe	KBR	UHDE
Frontend technologies	SMR	+	+	+
	ATR	+	-	-
Proposed for 5200 MTPD		ATR	SMR + KRES + SR	SMR +SR
Engineering services	PDP	Yes, Denmark	Yes, US	Yes, Germany
	EPC	Contractor, Flexible	Contractor, Flexible	Contractor, Flexible
Catalyst sourcing		In-House	JM	JM or Clariant
Industrial experience (5200 MTPD)	Frontend	6	0	0
	Backend	1	0	0

Figure 3 – Vendor selection matrix

## PROCESS LAYOUT

The Topsoe SynCOR Ammonia™ process enables a large single train capacity. The Capex saving come in part due to the elimination of the SMR but also from creative engineering of the ammonia synthesis processes that eliminates several sections in traditional plant design. The design provides sufficient steam to power itself with excess for export. The plant has two principal processes divided into sub processes process sections (Figure 4).

### A. Syngas generation

1. Desulfurization section
2. Reforming section

### B. Ammonia production

3. Syngas conditioning
4. Ammonia synthesis section
5. Ammonia cooling/refrigeration section

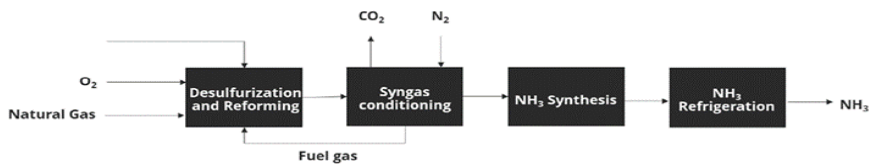

Figure 4 - Block Flow Diagram

## TECHNICAL DESCRIPTION & ANALYSIS

These discussions are relevant for all plants from 3,000 to 6,000 MTPD. The difference between a grey ammonia plant (Figure 5) and a Blue Ammonia plant (Figure 6) can be seen in the following two process flow diagrams (PFD).

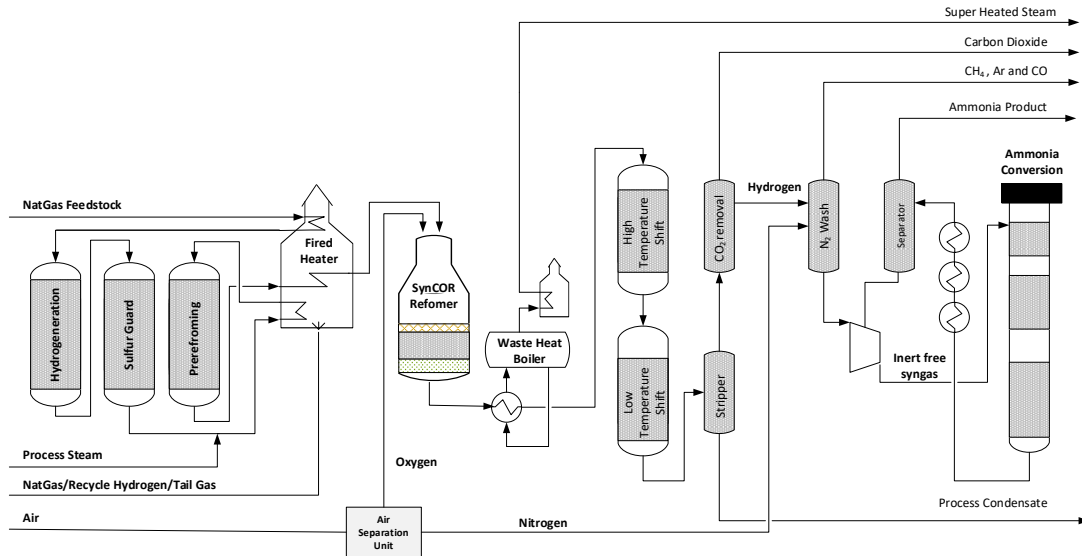

Figure 5 - Grey Ammonia Process Flow Diagram

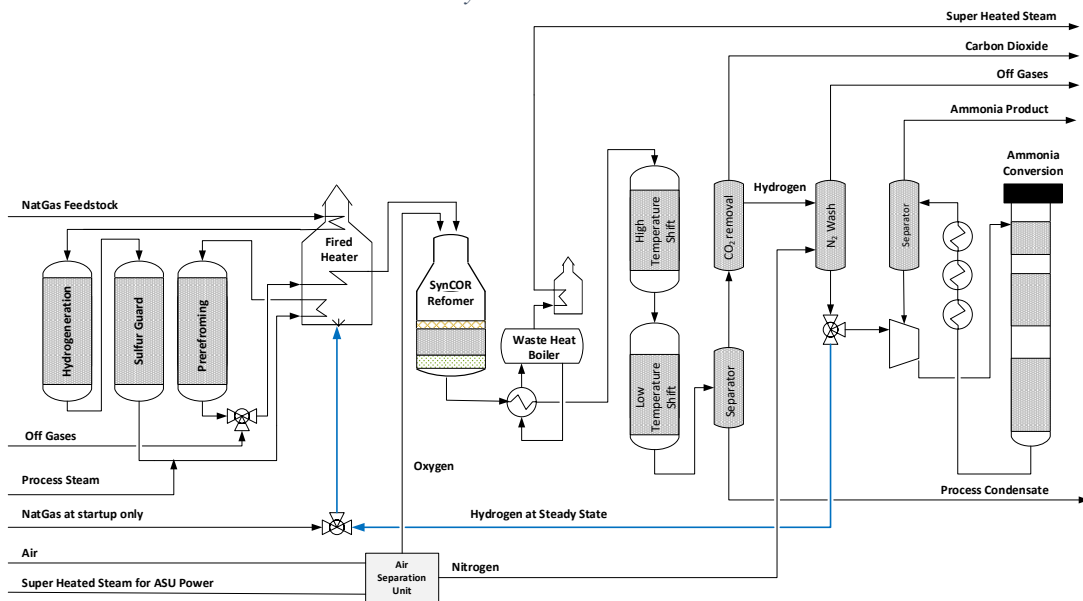

Diagram  
Figure 6 - Blue Ammonia Process Flow Diagram

Note that in the Blue Ammonia process, as with Blue Methanol, a hydrogen stream is produced in a water gas shift (WGS) and routed to the preheater to replace natural gas used to preheat the feedstock. This eliminates the CO<sub>2</sub> emissions from the preheater, which is the primary source of emission from the facility.

However, in the case of ammonia, the WGS is already an integral part of the process thus it is simply a matter of resizing the equipment and producing extra carbon monoxide (CO) required.

### 1. DESULFURIZATION SECTION

The process is based on utilizing 100% methane as feedstock. In the desulfurization section any sulfur and other impurities are removed from the methane via a hydrogenation step where sulfur components are converted to

saturated hydrocarbon and hydrogen sulfide over a Topsoe hydrogenation catalyst bed. Thereafter the hydrogen sulfide is absorbed in a sulfur absorber loaded with Topsoe sulfur absorption catalyst. The feed is also preheated.

## 2. REFORMING SECTION

SynCOR™ is not a new development. Topsoe has designed ATRs for many years. The first ATR was installed in an ammonia plant in 1958.

Since then, the SynCOR™ technology has been found useful in many different types of process plants such as gas-to-liquids (GTL) plants, methanol plants, and for various synthesis gas applications. This means that the knowledge and experience from these technologies can advantageously be transferred and used also for designing very large ammonia plants.

Figure 7 illustrates how the purified natural gas is mixed with steam to the required steam to carbon ratio before being routed to an adiabatic pre-reformer loaded with Topsoe pre-reformer catalyst. In the pre-reformer, all higher hydrocarbons are converted into a mixture of hydrogen, carbon monoxide, carbon dioxide, and methane by the steam reforming and water gas shift reactions. The pre-reformed natural gas and steam together with a mixture of steam and high purity oxygen enters the Cool Tip Swirler (CTS) burner at the top of the autothermal reformer.

Exothermic reactions occur within the combustion zone and catalytic zone whereby the overall hydrocarbon reforming occurs.

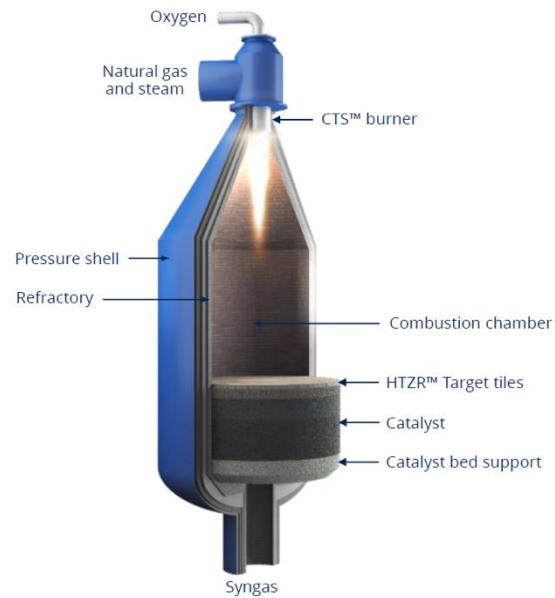
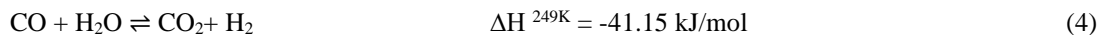
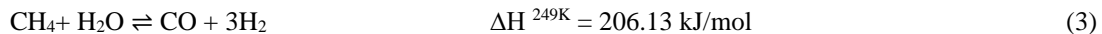

Figure 7 - Topsoe SynCOR™ Reformer

### Combustion zone



### Thermal and catalytic zones



A critical parameter for satisfactory autothermal reformer performance is efficient mixing of the process gas and air or oxygen. Uneven mixing can result in large temperature variations above and into the catalyst bed, causing variations in the degree of methane reforming achieved and often yielding a poor overall approach to reforming equilibrium, even with a highly active secondary reforming catalyst. The efficiency of gas mixing is primarily a function of the burner design. In addition to causing inefficient gas mixing, a poorly designed burner can damage the vessel walls, refractory or even the burner itself due to impingement of hot gas and/or flame in these areas.

In autothermal and oxygen-blown reformers, the enriched air or oxygen is typically supplied at high pressures, thereby allowing for the possibility of a higher pressure drop across the reactor burner. For these services, Topsoe uses the CTS burner (Figure 8).

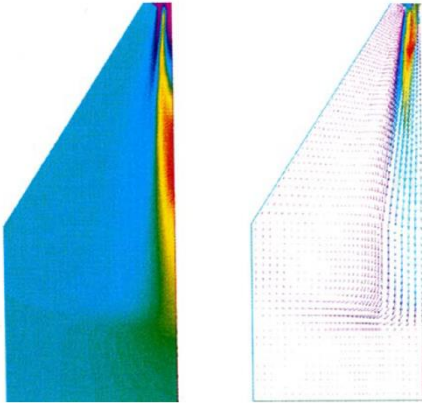

Figure 9 - Temperature distribution and the velocity profiles



Figure 8 – Topsoe CTS

Figure 9 illustrates a Computational Fluid Dynamics (CFD) profile of a CTS burner, showing the maintenance of low temperatures at the vessel walls and an efficient gas circulation pattern, thereby producing optimal mixing and minimizing reactor damage.

A critical attribute of the SynCOR™ is its low steam to carbon ratio (S/C) enabled this through the development and commercialization of its high temperature shift catalyst, SK-501 Flex™. The conventional SMR based plants operate at S/C ratio around 3 while a SynCOR Ammonia™ plant operates at S/C ratio around 0.6. Consequently, steam throughput decreases by 80% enabling significantly reduced pipe and equipment sizes not only in the frontend (reforming, shift, and CO<sub>2</sub> removal sections), but also in the backend (ammonia synthesis section) including a smaller synthesis gas compressor/recirculation, ammonia converter, and high-pressure heat exchangers.

Waste heat from the synthesis gas is used to produce steam for internal consumption as well as for electricity generation. In the SynCOR Blue Ammonia™ process enough steam is generated to provide the electricity requirements for the air separation unit (ASU) and ISBL motors under normal operating conditions.

The process gas waste heat boiler (WHB) is a critical piece of equipment cooling the hot synthesis gas exiting the SynCOR reformer. The heat from the process gas is utilized to generate high-pressure and high-quality steam for the process and to drive turbines. The Topsoe WHB is based on a thin flexible tube sheet combined with a unique





This design generates an inert-free synthesis gas, which provides benefits in terms of less need of compressor/recycle power and significantly reduced sizes of high-pressure equipment and piping.

The inert containing stream is routed to the fired heater in order to drive the combustion process as a low carbon content fuel gas stream.

After the shift section, by-products will be partly condensed out together with the process condensate. The process condensate and washing water, which contains the by-products from the shift, flows to a process condensate stripper, where practically all shift by-products are stripped off. This has several advantages:

- The main by-product formation is by equilibrium reactions. Adding an equilibrium byproduct component to the feed of an equilibrium byproduct generator, such as a shift reactor, will stop further formation of that component. The main shift by-product, methanol, is formed by an equilibrium reaction.
- Dissolved synthesis gas in the process condensate returns to the process.
- The stripper steam will increase the S/C in the shift section.

The CO<sub>2</sub> is removed using the OASE process by BASF. CO<sub>2</sub> is removed by absorption in the hot aqueous potassium carbonates solution containing a ≈30 wt% potassium carbonate (K<sub>2</sub>CO<sub>3</sub>) partly converted into bicarbonate (KHCO<sub>3</sub>). The solution further contains activators, glycine, diethanolamine (DEA), and vanadium oxides as corrosion inhibitor. The reason for keeping the solution hot is to increase the rate of absorption and keep the bicarbonate dissolved. Another advantage is that the temperature is approximately the same in the absorber and in the regenerators, keeping the boiling point temperature of the solution at the pressure prevailing in each of the two regenerators. Thus, it is not necessary to supply heat to the solution before the regeneration. The important point is that the purified gas has very low CO<sub>2</sub> slippage (about 0.03 wt% dry CO<sub>2</sub>).

#### 4. AMMONIA SYNTHESIS SECTION

In ammonia synthesis, Topsoe uses its updated version of the radial flow converter – the S-300. The S-300 radial flow converters are proven by more than 50 installations worldwide, making it the benchmark within the ammonia industry today.

The S-300 converter features three radial flow catalyst beds and two interbed heat exchangers. In the S-300 converter, the catalyst volume can be reduced by approximately 20% compared with the previous version for the same ammonia conversion.

The synthesis gas is compressed and mixed with circulating synthesis gas from the ammonia loop recycle compressor, before being preheated and fed to the ammonia converter. In the ammonia converter, the hydrogen and nitrogen are converted into ammonia according to reaction (1).

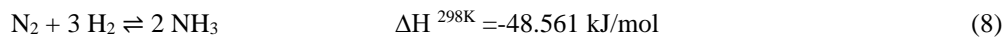

SynCOR Ammonia™ plants also benefit from an inert-free ammonia synthesis, with the required nitrogen admitted just upstream of the ammonia synthesis section, whereas the conventional plant introduces the nitrogen in the reforming section.

The ammonia converter is a three-catalyst bed converter with radial flow through the catalyst beds. Between each of the catalyst beds, an interbed heat exchanger is installed and the interbed heat exchangers serve the purpose of removing the reaction heat prior to entering the next catalyst bed. This is necessary, as the ammonia synthesis reaction is an equilibrium reaction favored by low temperatures. However, since the reaction velocity is favored by high temperatures, the actual operating temperatures are based on a compromise.

The ammonia synthesis loop is an inert free loop, and this means that the content of dissolved inert gases like methane and noble gases are so low that a purge system including a hydrogen recovery section is not needed.

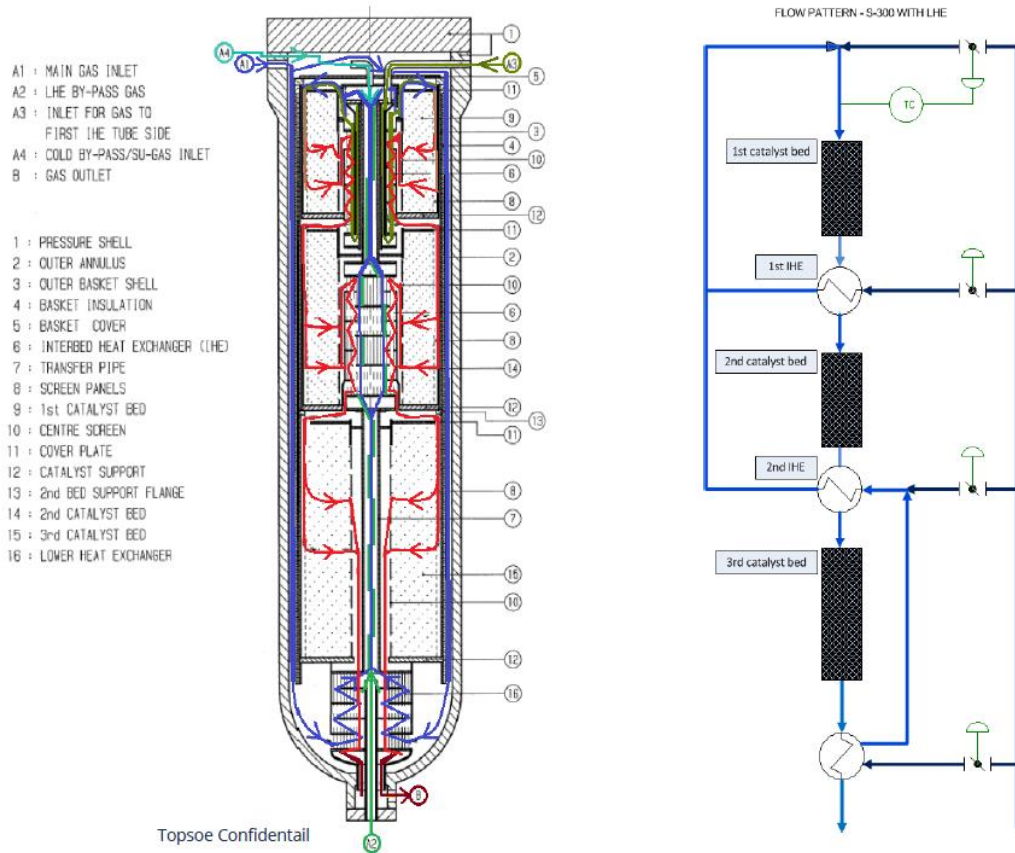

Figure 12 – Ammonia Converter S-300

Topsoe’s ammonia synthesis technology is based on radial flow converters where the synthesis of ammonia from hydrogen and nitrogen takes place. Topsoe pioneered the technology with the installation of the first radial flow converters in the 1960s. Since then, continuous development has resulted in a comprehensive portfolio of radial flow converter designs to meet the multifaceted requirements in the industry.



- 100% radial flow through the catalyst beds to obtain low pressure and high conversion with a small size catalyst particle,
- Indirect cooling of the gas in the heat exchangers between the catalyst beds instead of quenching, to avoid dilution of the converted gas,
- Total converter feed flow passes through all beds fully utilizing the total installed catalyst volume,
- Stable operation with great flexibility in operating range, and
- Simple temperature control.

At startup the converter must be preheated. Traditionally this has been done with natural gas heaters. Topsoe's electrical start-up heater provides with a safe, quick, and energy-efficient solution to the start-up. Compared to conventional gas-fired heaters, the Topsoe electrical heater offers compact, safe, remotely controlled, and quick start-up of an ammonia plant. Intrinsically safe for hazardous areas with pressurized terminal boxes, with no explosion hazard. The S-300 heater has a hairpin-type arrangement, located inside the converter, allowing the heat duty to be 50% lower than an external arrangement.

## 5. AMMONIA COOLING/REFRIGERATION SECTION

The synthesis gas leaving the ammonia converter is cooled, and the ammonia is condensed in the loop air cooler and the subsequent ammonia chiller (Figure 13). The liquid ammonia is separated from the synthesis gas in the ammonia separator and the ammonia is treated further in the ammonia refrigeration section.

The ammonia refrigeration section:

- Generates the low temperatures needed to condense the produced ammonia
- Cools the product ammonia
- Removes some of the dissolved inert gases from the ammonia

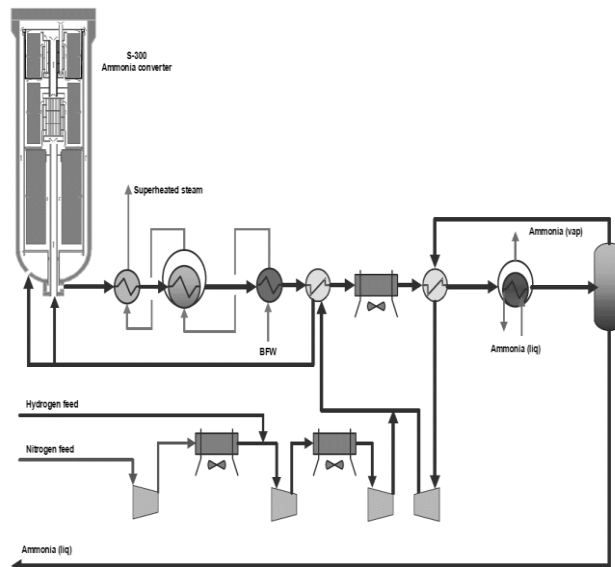
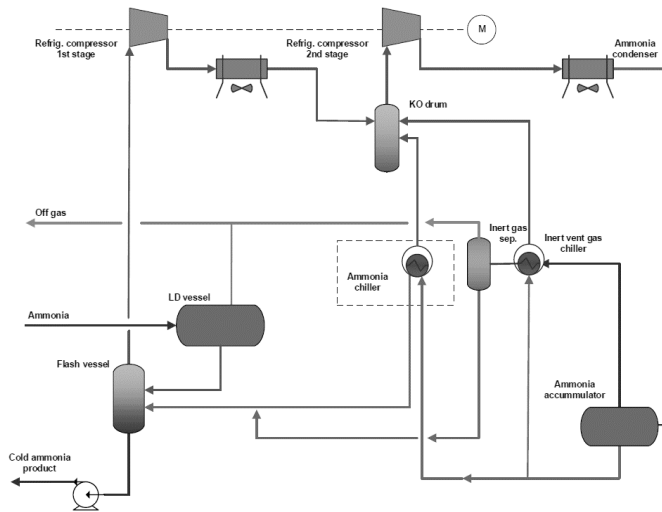

Figure 13 - Ammonia Loop Process Layout

The layout of the ammonia refrigeration section is as shown in figure 14 hereunder.



The section comprises a compressor part, an accumulator and two ammonia chillers. The inerts present in the liquid ammonia are removed by flashing in the accumulator and the ammonia is recovered.

The product ammonia is delivered at battery limit at  $-32^{\circ}\text{C}$  with a composition of:

-	H <sub>2</sub>	0.06%
-	CH <sub>4</sub>	0.03%
-	N <sub>2</sub>	0.02%
-	Ar	64 ppm

Figure 14 - Ammonia Refrigeration Process Layout

## AMMONIA HANDLING

Liquefied ammonia from production plants is either used directly in downstream plants or transferred to storage tanks. From these the ammonia can be transferred to road tankers, rail tank cars, or ships. Ammonia is usually stored by using one or other of three methods:

- Refrigerated storage in large tanks with a typical capacity of 10,000 tons (up to 50,000)

Emissions during normal operation are negligible. Major leaks of ammonia from storage tanks are almost unknown, with most of the leaks which do occur being during transport or transfer. A well designed, constructed, operated, and maintained installation has a very low probability of an ammonia leak of hazardous proportions.

## STORAGE TANKS

Anhydrous ammonia is stored in three types of tanks as outlined below:

- Fully refrigerated at a temperature of about  $-33^{\circ}\text{C}$ , these tanks are provided with refrigeration equipment
- Non-refrigerated tanks in which the ammonia is stored at ambient temperature
- Semi-refrigerated spheres

Refrigerated storage is preferred for storage of large quantities of liquid ammonia. The initial release of ammonia in the case of a line or tank failure is much slower than with pressurized ammonia.

There are several construction types for the storage of refrigerated liquid products. The most important types are:

- Single containment: a single-wall insulated tank, normally with a containment bund around it.

- Double containment: this type of storage tank has two vertical walls, both of which are designed to contain the stored amount of liquid and withstand the hydrostatic pressure of the liquid. The roof rests on the inner wall.
- Full containment: the two walls of this closed storage tank are also designed to contain the stored amount of liquid, but in this case the roof rests on the outer wall.

The tank must be constructed in conformity with an agreed code for the construction of pressure vessels or storage tanks, taking account of its pressure and operating temperature. The design and materials of construction of the tank should be checked by consulting an appropriate national standard. These could make demands on the blast resistance of storage tanks in some cases.

The storage tank must be safeguarded against high pressure, and in the case of refrigerated liquid ammonia, also against a pressure below the minimum design pressure. The ingress of warm ammonia into cold ammonia must be avoided to eliminate risk of excessive evaporation and the “roll-over” phenomenon. All storage tanks should be equipped with two independent level indicators, each having a high-level alarm.

An automatic cut-off valve, operated by a very high-level alarm instrument, should be installed on the feeding line.

In cases of refrigerated liquid ammonia, storage tanks must be equipped with a recompression installation to liquefy the boil-off. There should be at least two refrigeration units to allow proper maintenance and to prevent the emission of ammonia via the relief valves. Furthermore, an installed

**ATTACHMENT H**

**MATERIAL SAFETY DATA SHEETS**

# SAFETY DATA SHEET

## Ammonia

### Section 1. Identification

<b>GHS product identifier</b>	: Ammonia
<b>Chemical name</b>	: ammonia
<b>Other means of identification</b>	: ammonia; anhydrous ammonia
<b>Product type</b>	: Gas.
<b>Product use</b>	: Synthetic/Analytical chemistry.
<b>Synonym</b>	: ammonia; anhydrous ammonia
<b>SDS #</b>	: 001003
<b>Supplier's details</b>	: Airgas USA, LLC and its affiliates 259 North Radnor-Chester Road Suite 100 Radnor, PA 19087-5283 1-610-687-5253
<b>24-hour telephone</b>	: 1-866-734-3438

### Section 2. Hazards identification

<b>OSHA/HCS status</b>	: This material is considered hazardous by the OSHA Hazard Communication Standard (29 CFR 1910.1200).
<b>Classification of the substance or mixture</b>	: FLAMMABLE GASES - Category 2 GASES UNDER PRESSURE - Liquefied gas ACUTE TOXICITY (inhalation) - Category 4 SKIN CORROSION - Category 1 SERIOUS EYE DAMAGE - Category 1 AQUATIC HAZARD (ACUTE) - Category 1

#### GHS label elements

##### Hazard pictograms



##### Signal word

: Danger

##### Hazard statements

: Flammable gas.  
May form explosive mixtures with air.  
Contains gas under pressure; may explode if heated.  
May displace oxygen and cause rapid suffocation.  
Harmful if inhaled.  
Causes severe skin burns and eye damage.  
Very toxic to aquatic life.

#### Precautionary statements

##### General

: Read and follow all Safety Data Sheets (SDS'S) before use. Close valve after each use and when empty. Use equipment rated for cylinder pressure. Do not open valve until connected to equipment prepared for use. Use a back flow preventative device in the piping. Use only equipment of compatible materials of construction. Always keep container in upright position. Approach suspected leak area with caution.

##### Prevention

: Wear protective gloves. Wear eye or face protection. Wear protective clothing. Keep away from heat, hot surfaces, sparks, open flames and other ignition sources. No smoking. Use only outdoors or in a well-ventilated area. Avoid release to the environment. Avoid breathing gas. Wash hands thoroughly after handling.

## Section 2. Hazards identification

- Response** : Collect spillage. IF INHALED: Remove person to fresh air and keep comfortable for breathing. Immediately call a POISON CENTER or physician. IF SWALLOWED: Immediately call a POISON CENTER or physician. Rinse mouth. Do NOT induce vomiting. IF ON SKIN (or hair): Take off immediately all contaminated clothing. Rinse skin with water or shower. Wash contaminated clothing before reuse. Immediately call a POISON CENTER or physician. IF IN EYES: Rinse cautiously with water for several minutes. Remove contact lenses, if present and easy to do. Continue rinsing. Immediately call a POISON CENTER or physician. Leaking gas fire: Do not extinguish, unless leak can be stopped safely. Eliminate all ignition sources if safe to do so.
- Storage** : Store locked up. Protect from sunlight. Store in a well-ventilated place.
- Disposal** : Dispose of contents and container in accordance with all local, regional, national and international regulations.
- Hazards not otherwise classified** : In addition to any other important health or physical hazards, this product may displace oxygen and cause rapid suffocation.

## Section 3. Composition/information on ingredients

- Substance/mixture** : Substance
- Chemical name** : ammonia
- Other means of identification** : ammonia; anhydrous ammonia
- Product code** : 001003

### CAS number/other identifiers

- CAS number** : 7664-41-7

Ingredient name	%	CAS number
ammonia	100	7664-41-7

Any concentration shown as a range is to protect confidentiality or is due to batch variation.

**There are no additional ingredients present which, within the current knowledge of the supplier and in the concentrations applicable, are classified as hazardous to health or the environment and hence require reporting in this section.**

Occupational exposure limits, if available, are listed in Section 8.

## Section 4. First aid measures

### Description of necessary first aid measures

- Eye contact** : Immediately flush eyes with plenty of water, occasionally lifting the upper and lower eyelids. Check for and remove any contact lenses. Continue to rinse for at least 10 minutes. Get medical attention immediately. Call medical doctor or poison control center immediately. Chemical burns must be treated promptly by a physician.
- Inhalation** : Remove victim to fresh air and keep at rest in a position comfortable for breathing. If it is suspected that fumes are still present, the rescuer should wear an appropriate mask or self-contained breathing apparatus. If not breathing, if breathing is irregular or if respiratory arrest occurs, provide artificial respiration or oxygen by trained personnel. It may be dangerous to the person providing aid to give mouth-to-mouth resuscitation. If unconscious, place in recovery position and get medical attention immediately. Maintain an open airway. Loosen tight clothing such as a collar, tie, belt or waistband. Get medical attention immediately. Call medical doctor or poison control center immediately. In case of inhalation of decomposition products in a fire, symptoms may be delayed. The exposed person may need to be kept under medical surveillance for 48 hours.
- Skin contact** : Flush contaminated skin with plenty of water. Remove contaminated clothing and shoes. To avoid the risk of static discharges and gas ignition, soak contaminated clothing thoroughly with water before removing it. Continue to rinse for at least 10 minutes. Get medical attention immediately. Call medical doctor or poison control center immediately. Chemical burns must be treated promptly by a physician. Wash clothing before reuse. Clean shoes thoroughly before reuse.
- Ingestion** : As this product is a gas, refer to the inhalation section.

## Section 4. First aid measures

### Most important symptoms/effects, acute and delayed

#### Potential acute health effects

- Eye contact** : Causes serious eye damage.
- Inhalation** : Harmful if inhaled.
- Skin contact** : Causes severe burns.
- Frostbite** : Try to warm up the frozen tissues and seek medical attention.
- Ingestion** : As this product is a gas, refer to the inhalation section.

#### Over-exposure signs/symptoms

- Eye contact** : Adverse symptoms may include the following:., pain, watering, redness
- Inhalation** : No specific data.
- Skin contact** : Adverse symptoms may include the following:., pain or irritation, redness, blistering may occur
- Ingestion** : Adverse symptoms may include the following:., stomach pains

### Indication of immediate medical attention and special treatment needed, if necessary

- Notes to physician** : In case of inhalation of decomposition products in a fire, symptoms may be delayed. The exposed person may need to be kept under medical surveillance for 48 hours.
- Specific treatments** : No specific treatment.
- Protection of first-aiders** : No action shall be taken involving any personal risk or without suitable training. If it is suspected that fumes are still present, the rescuer should wear an appropriate mask or self-contained breathing apparatus. It may be dangerous to the person providing aid to give mouth-to-mouth resuscitation. Wash contaminated clothing thoroughly with water before removing it, or wear gloves.

See toxicological information (Section 11)

## Section 5. Fire-fighting measures

### Extinguishing media

- Suitable extinguishing media** : Use an extinguishing agent suitable for the surrounding fire.
- Unsuitable extinguishing media** : None known.

- Specific hazards arising from the chemical** : Contains gas under pressure. Flammable gas. In a fire or if heated, a pressure increase will occur and the container may burst, with the risk of a subsequent explosion. This material is very toxic to aquatic life. Fire water contaminated with this material must be contained and prevented from being discharged to any waterway, sewer or drain.

- Hazardous thermal decomposition products** : Decomposition products may include the following materials:  
nitrogen oxides

- Special protective actions for fire-fighters** : Promptly isolate the scene by removing all persons from the vicinity of the incident if there is a fire. No action shall be taken involving any personal risk or without suitable training. Contact supplier immediately for specialist advice. Move containers from fire area if this can be done without risk. Use water spray to keep fire-exposed containers cool. If involved in fire, shut off flow immediately if it can be done without risk. If this is impossible, withdraw from area and allow fire to burn. Fight fire from protected location or maximum possible distance. Eliminate all ignition sources if safe to do so.

- Special protective equipment for fire-fighters** : Fire-fighters should wear appropriate protective equipment and self-contained breathing apparatus (SCBA) with a full face-piece operated in positive pressure mode.

## Section 6. Accidental release measures

### Personal precautions, protective equipment and emergency procedures

- For non-emergency personnel** : Accidental releases pose a serious fire or explosion hazard. No action shall be taken involving any personal risk or without suitable training. Evacuate surrounding areas. Keep unnecessary and unprotected personnel from entering. Shut off all ignition sources. No flares, smoking or flames in hazard area. Do not breathe gas. Provide adequate ventilation. Wear appropriate respirator when ventilation is inadequate. Put on appropriate personal protective equipment.
- For emergency responders** : If specialized clothing is required to deal with the spillage, take note of any information in Section 8 on suitable and unsuitable materials. See also the information in "For non-emergency personnel".

- Environmental precautions** : Ensure emergency procedures to deal with accidental gas releases are in place to avoid contamination of the environment. Inform the relevant authorities if the product has caused environmental pollution (sewers, waterways, soil or air). Water polluting material. May be harmful to the environment if released in large quantities. Collect spillage.

### Methods and materials for containment and cleaning up

- Small spill** : Immediately contact emergency personnel. Stop leak if without risk. Use spark-proof tools and explosion-proof equipment.
- Large spill** : Immediately contact emergency personnel. Stop leak if without risk. Use spark-proof tools and explosion-proof equipment. Note: see Section 1 for emergency contact information and Section 13 for waste disposal.

## Section 7. Handling and storage

### Precautions for safe handling

- Protective measures** : Put on appropriate personal protective equipment (see Section 8). Contains gas under pressure. Do not get in eyes or on skin or clothing. Do not breathe gas. Avoid release to the environment. Use only with adequate ventilation. Wear appropriate respirator when ventilation is inadequate. Do not enter storage areas and confined spaces unless adequately ventilated. Store and use away from heat, sparks, open flame or any other ignition source. Empty containers retain product residue and can be hazardous. Do not puncture or incinerate container. Use equipment rated for cylinder pressure. Close valve after each use and when empty. Protect cylinders from physical damage; do not drag, roll, slide, or drop. Use a suitable hand truck for cylinder movement.

- Advice on general occupational hygiene** : Eating, drinking and smoking should be prohibited in areas where this material is handled, stored and processed. Workers should wash hands and face before eating, drinking and smoking. Remove contaminated clothing and protective equipment before entering eating areas. See also Section 8 for additional information on hygiene measures.

- Conditions for safe storage, including any incompatibilities** : Store in accordance with local regulations. Store in a segregated and approved area. Store away from direct sunlight in a dry, cool and well-ventilated area, away from incompatible materials (see Section 10). Store locked up. Eliminate all ignition sources. Keep container tightly closed and sealed until ready for use. Cylinders should be stored upright, with valve protection cap in place, and firmly secured to prevent falling or being knocked over. Cylinder temperatures should not exceed 52 °C (125 °F). Refer to ANSI/CGA G-2.1, Section 5.13 for electrical classification of anhydrous ammonia storage and handling areas. Where anhydrous ammonia is stored indoors, use electrical (ventilating, lighting and material handling) equipment with the appropriate electrical classification rating and use only non-sparking tools.



## Section 8. Exposure controls/personal protection

### Control parameters

#### Occupational exposure limits

Ingredient name	Exposure limits
ammonia	<p><b>California PEL for Chemical Contaminants ( Table AC-1) (United States).</b>            PEL: 25 ppm 8 hours.            STEL: 35 ppm 15 minutes.</p> <p><b>ACGIH TLV (United States, 3/2017).</b>            TWA: 25 ppm 8 hours.            TWA: 17 mg/m<sup>3</sup> 8 hours.            STEL: 35 ppm 15 minutes.            STEL: 24 mg/m<sup>3</sup> 15 minutes.</p> <p><b>OSHA PEL 1989 (United States, 3/1989).</b>            STEL: 35 ppm 15 minutes.            STEL: 27 mg/m<sup>3</sup> 15 minutes.</p> <p><b>NIOSH REL (United States, 10/2016).</b>            TWA: 25 ppm 10 hours.            TWA: 18 mg/m<sup>3</sup> 10 hours.            STEL: 35 ppm 15 minutes.            STEL: 27 mg/m<sup>3</sup> 15 minutes.</p> <p><b>OSHA PEL (United States, 6/2016).</b>            TWA: 50 ppm 8 hours.            TWA: 35 mg/m<sup>3</sup> 8 hours.</p>

#### Appropriate engineering controls

- : Use only with adequate ventilation. Use process enclosures, local exhaust ventilation or other engineering controls to keep worker exposure to airborne contaminants below any recommended or statutory limits. The engineering controls also need to keep gas, vapor or dust concentrations below any lower explosive limits. Use explosion-proof ventilation equipment.

#### Environmental exposure controls

- : Emissions from ventilation or work process equipment should be checked to ensure they comply with the requirements of environmental protection legislation. In some cases, fume scrubbers, filters or engineering modifications to the process equipment will be necessary to reduce emissions to acceptable levels.

### Individual protection measures

#### Hygiene measures

- : Wash hands, forearms and face thoroughly after handling chemical products, before eating, smoking and using the lavatory and at the end of the working period. Appropriate techniques should be used to remove potentially contaminated clothing. Wash contaminated clothing before reusing. Ensure that eyewash stations and safety showers are close to the workstation location.

#### Eye/face protection

- : Safety eyewear complying with an approved standard should be used when a risk assessment indicates this is necessary to avoid exposure to liquid splashes, mists, gases or dusts. If contact is possible, the following protection should be worn, unless the assessment indicates a higher degree of protection: chemical splash goggles and/or face shield. If inhalation hazards exist, a full-face respirator may be required instead.

#### Skin protection

##### Hand protection

- : Chemical-resistant, impervious gloves complying with an approved standard should be worn at all times when handling chemical products if a risk assessment indicates this is necessary. Considering the parameters specified by the glove manufacturer, check during use that the gloves are still retaining their protective properties. It should be noted that the time to breakthrough for any glove material may be different for different glove manufacturers. In the case of mixtures, consisting of several substances, the protection time of the gloves cannot be accurately estimated.

##### Body protection

- : Personal protective equipment for the body should be selected based on the task being performed and the risks involved and should be approved by a specialist before handling this product. When there is a risk of ignition from static electricity, wear anti-static protective clothing. For the greatest protection from static discharges, clothing should include anti-static overalls, boots and gloves.

## Section 8. Exposure controls/personal protection

- Other skin protection** : Appropriate footwear and any additional skin protection measures should be selected based on the task being performed and the risks involved and should be approved by a specialist before handling this product.
- Respiratory protection** : Based on the hazard and potential for exposure, select a respirator that meets the appropriate standard or certification. Respirators must be used according to a respiratory protection program to ensure proper fitting, training, and other important aspects of use. Respirator selection must be based on known or anticipated exposure levels, the hazards of the product and the safe working limits of the selected respirator.

## Section 9. Physical and chemical properties

### Appearance

- Physical state** : Gas. [Compressed gas.]
- Color** : Colorless.
- Odor** : Pungent.
- Odor threshold** : Not available.
- pH** : Approx. 11.6
- Melting point** : -77.7°C (-107.9°F)
- Boiling point** : -33°C (-27.4°F)
- Critical temperature** : 132.85°C (271.1°F)
- Flash point** : Not available.
- Evaporation rate** : Not available.
- Flammability (solid, gas)** : Extremely flammable in the presence of the following materials or conditions: oxidizing materials.
- Lower and upper explosive (flammable) limits** : Lower: 16%  
Upper: 25%
- Vapor pressure** : 114.1 (psig)
- Vapor density** : 0.59 (Air = 1)
- Specific Volume (ft<sup>3</sup>/lb)** : 20.79
- Gas Density (lb/ft<sup>3</sup>)** : 0.0481 (32°C / 89.6 to °F)
- Relative density** : SPECIFIC GRAVITY (AIR=1): @ 70°F (21.1°C) = 0.59
- Solubility** : Soluble in water. Soluble in alcohol and ether.
- Solubility in water** : 540 g/l
- Partition coefficient: n-octanol/water** : Not available.
- Auto-ignition temperature** : 651°C (1203.8°F)
- Decomposition temperature** : Not available.
- Viscosity** : Not applicable.
- Flow time (ISO 2431)** : Not available.
- Molecular weight** : 17.03 g/mole
- Aerosol product**
- Heat of combustion** : -18589392 J/kg

## Section 10. Stability and reactivity

- Reactivity** : No specific test data related to reactivity available for this product or its ingredients.
- Chemical stability** : The product is stable.
- Possibility of hazardous reactions** : Under normal conditions of storage and use, hazardous reactions will not occur.
- Conditions to avoid** : Avoid all possible sources of ignition (spark or flame). Do not pressurize, cut, weld, braze, solder, drill, grind or expose containers to heat or sources of ignition.

## Section 10. Stability and reactivity

**Incompatible materials** : Oxidizers and Yellow Metals (brass & copper)

**Hazardous decomposition products** : Under normal conditions of storage and use, hazardous decomposition products should not be produced.

**Hazardous polymerization** : Under normal conditions of storage and use, hazardous polymerization will not occur.

## Section 11. Toxicological information

### Information on toxicological effects

#### Acute toxicity

Product/ingredient name	Result	Species	Dose	Exposure
ammonia	LC50 Inhalation Gas.	Rat	7338 ppm	1 hours

#### Irritation/Corrosion

Not available.

#### Sensitization

Not available.

#### Mutagenicity

Not available.

#### Carcinogenicity

Not available.

#### Reproductive toxicity

Not available.

#### Teratogenicity

Not available.

#### Specific target organ toxicity (single exposure)

Not available.

#### Specific target organ toxicity (repeated exposure)

Not available.

#### Aspiration hazard

Not available.

**Information on the likely routes of exposure** : Not available.

### Potential acute health effects

**Eye contact** : Causes serious eye damage.

**Inhalation** : Harmful if inhaled.

**Skin contact** : Causes severe burns.

**Ingestion** : As this product is a gas, refer to the inhalation section.

### Symptoms related to the physical, chemical and toxicological characteristics

**Eye contact** : Adverse symptoms may include the following:., pain, watering, redness

**Inhalation** : No specific data.

**Skin contact** : Adverse symptoms may include the following:., pain or irritation, redness, blistering may occur

## Section 11. Toxicological information

**Ingestion** : Adverse symptoms may include the following:, stomach pains

### Delayed and immediate effects and also chronic effects from short and long term exposure

#### Short term exposure

**Potential immediate effects** : Not available.

**Potential delayed effects** : Not available.

#### Long term exposure

**Potential immediate effects** : Not available.

**Potential delayed effects** : Not available.

#### Potential chronic health effects

Not available.

**General** : No known significant effects or critical hazards.

**Carcinogenicity** : No known significant effects or critical hazards.

**Mutagenicity** : No known significant effects or critical hazards.

**Teratogenicity** : No known significant effects or critical hazards.

**Developmental effects** : No known significant effects or critical hazards.

**Fertility effects** : No known significant effects or critical hazards.

### Numerical measures of toxicity

#### Acute toxicity estimates

Not available.

**Other information** : IDLH : 300 ppm

## Section 12. Ecological information

### Toxicity

Product/ingredient name	Result	Species	Exposure
ammonia	Acute EC50 29.2 mg/l Marine water	Algae - Ulva fasciata - Zoea	96 hours
	Acute LC50 2080 µg/l Fresh water	Crustaceans - Gammarus pulex	48 hours
	Acute LC50 0.53 ppm Fresh water	Daphnia - Daphnia magna	48 hours
	Acute LC50 300 µg/l Fresh water	Fish - Hypophthalmichthys nobilis	96 hours
	Chronic NOEC 0.204 mg/l Marine water	Fish - Dicentrarchus labrax	62 days

### Persistence and degradability

Not available.

### Bioaccumulative potential

Not available.

### Mobility in soil

**Soil/water partition coefficient (K<sub>oc</sub>)** : Not available.

**Other adverse effects** : No known significant effects or critical hazards.

## Section 13. Disposal considerations

**Disposal methods** : The generation of waste should be avoided or minimized wherever possible. Disposal of this product, solutions and any by-products should at all times comply with the requirements of environmental protection and waste disposal legislation and any regional local authority requirements. Dispose of surplus and non-recyclable products via a licensed waste disposal contractor. Waste should not be disposed of untreated to the sewer unless fully compliant with the requirements of all authorities with jurisdiction. Empty Airgas-owned pressure vessels should be returned to Airgas. Waste packaging should be recycled. Incineration or landfill should only be considered when recycling is not feasible. This material and its container must be disposed of in a safe way. Empty containers or liners may retain some product residues. Do not puncture or incinerate container.

## Section 14. Transport information

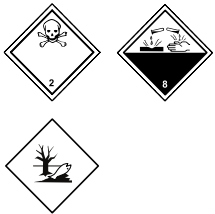
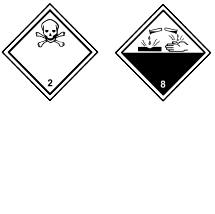
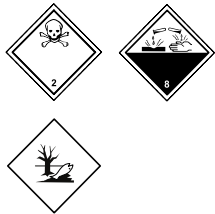
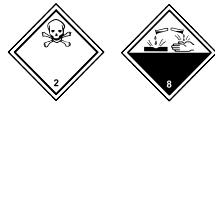
	DOT	TDG	Mexico	IMDG	IATA
<b>UN number</b>	UN1005	UN1005	UN1005	UN1005	UN1005
<b>UN proper shipping name</b>	AMMONIA, ANHYDROUS	AMMONIA, ANHYDROUS; OR ANHYDROUS AMMONIA	AMMONIA, ANHYDROUS	AMMONIA, ANHYDROUS	AMMONIA, ANHYDROUS
<b>Transport hazard class(es)</b>	2.2 	2.3 (8) 	2.3 (8) 	2.3 (8) 	2.3 (8) 
<b>Packing group</b>	-	-	-	-	-
<b>Environmental hazards</b>	Yes.	Yes.	Yes. The environmentally hazardous substance mark is not required.	Yes.	Yes. The environmentally hazardous substance mark is not required.

“Refer to CFR 49 (or authority having jurisdiction) to determine the information required for shipment of the product.”

**Additional information**

**DOT Classification**

: Inhalation hazard  
 This product is not regulated as a marine pollutant when transported on inland waterways in sizes of ≤5 L or ≤5 kg or by road, rail, or inland air in non-bulk sizes, provided the packagings meet the general provisions of §§ 173.24 and 173.24a.  
**Reportable quantity** 100 lbs / 45.4 kg. Package sizes shipped in quantities less than the product reportable quantity are not subject to the RQ (reportable quantity) transportation requirements.  
**Limited quantity** Yes.  
**Quantity limitation** Passenger aircraft/rail: Forbidden. Cargo aircraft: Forbidden.  
**Special provisions** 13,T50

**TDG Classification**

: Product classified as per the following sections of the Transportation of Dangerous Goods Regulations: 2.13-2.17 (Class 2), 2.40-2.42 (Class 8), 2.7 (Marine pollutant mark).  
 The marine pollutant mark is not required when transported by road or rail.  
**Explosive Limit and Limited Quantity Index** 0  
**ERAP Index** 3000  
**Passenger Carrying Ship Index** Forbidden  
**Passenger Carrying Road or Rail Index** Forbidden

## Section 14. Transport information

### Special provisions

- Mexico Classification** : Toxic Inhalation Hazard Zone D
- IMDG** : The marine pollutant mark is not required when transported in sizes of ≤5 L or ≤5 kg.
- IATA** : The environmentally hazardous substance mark may appear if required by other transportation regulations.
- Quantity limitation** Passenger and Cargo Aircraft: Forbidden. Cargo Aircraft Only: Forbidden. Limited Quantities - Passenger Aircraft: Forbidden.

**Special precautions for user** : **Transport within user's premises:** always transport in closed containers that are upright and secure. Ensure that persons transporting the product know what to do in the event of an accident or spillage.

**Transport in bulk according to Annex II of MARPOL and the IBC Code** : Not available.

## Section 15. Regulatory information

**U.S. Federal regulations** : **TSCA 8(a) CDR Exempt/Partial exemption:** Not determined  
**Clean Water Act (CWA) 311:** ammonia

**Clean Air Act (CAA) 112 regulated toxic substances:** ammonia

**Clean Air Act Section 112 (b) Hazardous Air Pollutants (HAPs)** : Not listed

**Clean Air Act Section 602 Class I Substances** : Not listed

**Clean Air Act Section 602 Class II Substances** : Not listed

**DEA List I Chemicals (Precursor Chemicals)** : Not listed

**DEA List II Chemicals (Essential Chemicals)** : Not listed

### SARA 302/304

#### Composition/information on ingredients

Name	%	EHS	SARA 302 TPQ		SARA 304 RQ	
			(lbs)	(gallons)	(lbs)	(gallons)
ammonia	100	Yes.	500	-	100	-

**SARA 304 RQ** : 100 lbs / 45.4 kg

### SARA 311/312

**Classification** : Refer to Section 2: Hazards Identification of this SDS for classification of substance.

### SARA 313

	Product name	CAS number	%
<b>Form R - Reporting requirements</b>	ammonia	7664-41-7	100
<b>Supplier notification</b>	ammonia	7664-41-7	100

SARA 313 notifications must not be detached from the SDS and any copying and redistribution of the SDS shall include copying and redistribution of the notice attached to copies of the SDS subsequently redistributed.

### State regulations

**Massachusetts** : This material is listed.

## Section 15. Regulatory information

**New York** : This material is listed.

**New Jersey** : This material is listed.

**Pennsylvania** : This material is listed.

### International regulations

#### Chemical Weapon Convention List Schedules I, II & III Chemicals

Not listed.

#### Montreal Protocol (Annexes A, B, C, E)

Not listed.

#### Stockholm Convention on Persistent Organic Pollutants

Not listed.

#### Rotterdam Convention on Prior Informed Consent (PIC)

Not listed.

#### UNECE Aarhus Protocol on POPs and Heavy Metals

Not listed.

### Inventory list

**Australia** : This material is listed or exempted.

**Canada** : This material is listed or exempted.

**China** : This material is listed or exempted.

**Europe** : This material is listed or exempted.

**Japan** : **Japan inventory (ENCS)**: This material is listed or exempted.  
**Japan inventory (ISHL)**: This material is listed or exempted.

**Malaysia** : This material is listed or exempted.

**New Zealand** : This material is listed or exempted.

**Philippines** : This material is listed or exempted.

**Republic of Korea** : This material is listed or exempted.

**Taiwan** : This material is listed or exempted.

**Thailand** : Not determined.

**Turkey** : This material is listed or exempted.

**United States** : This material is listed or exempted.

**Viet Nam** : Not determined.

## Section 16. Other information

### Hazardous Material Information System (U.S.A.)

Health	/	3
Flammability		1
Physical hazards		2

Caution: HMIS® ratings are based on a 0-4 rating scale, with 0 representing minimal hazards or risks, and 4 representing significant hazards or risks. Although HMIS® ratings and the associated label are not required on SDSs or products leaving a facility under 29 CFR 1910.1200, the preparer may choose to provide them. HMIS® ratings are to be used with a fully implemented HMIS® program. HMIS® is a registered trademark and service mark of the American Coatings Association, Inc.

The customer is responsible for determining the PPE code for this material. For more information on HMIS® Personal Protective Equipment (PPE) codes, consult the HMIS® Implementation Manual.

### National Fire Protection Association (U.S.A.)

## Section 16. Other information



Reprinted with permission from NFPA 704-2001, Identification of the Hazards of Materials for Emergency Response Copyright ©1997, National Fire Protection Association, Quincy, MA 02269. This reprinted material is not the complete and official position of the National Fire Protection Association, on the referenced subject which is represented only by the standard in its entirety.

Copyright ©2001, National Fire Protection Association, Quincy, MA 02269. This warning system is intended to be interpreted and applied only by properly trained individuals to identify fire, health and reactivity hazards of chemicals. The user is referred to certain limited number of chemicals with recommended classifications in NFPA 49 and NFPA 325, which would be used as a guideline only. Whether the chemicals are classified by NFPA or not, anyone using the 704 systems to classify chemicals does so at their own risk.

### Procedure used to derive the classification

Classification	Justification
FLAMMABLE GASES - Category 2	Expert judgment
GASES UNDER PRESSURE - Liquefied gas	Expert judgment
ACUTE TOXICITY (inhalation) - Category 4	Expert judgment
SKIN CORROSION - Category 1	Expert judgment
SERIOUS EYE DAMAGE - Category 1	Expert judgment
AQUATIC HAZARD (ACUTE) - Category 1	Expert judgment

### History

**Date of printing** : 1/10/2019

**Date of issue/Date of revision** : 1/10/2019

**Date of previous issue** : 10/9/2018

**Version** : 1.09

### Key to abbreviations

: ATE = Acute Toxicity Estimate  
 BCF = Bioconcentration Factor  
 GHS = Globally Harmonized System of Classification and Labelling of Chemicals  
 IATA = International Air Transport Association  
 IBC = Intermediate Bulk Container  
 IMDG = International Maritime Dangerous Goods  
 LogPow = logarithm of the octanol/water partition coefficient  
 MARPOL = International Convention for the Prevention of Pollution From Ships, 1973 as modified by the Protocol of 1978. ("Marpol" = marine pollution)  
 UN = United Nations

### References

: Not available.

### Notice to reader

To the best of our knowledge, the information contained herein is accurate. However, neither the above-named supplier, nor any of its subsidiaries, assumes any liability whatsoever for the accuracy or completeness of the information contained herein.

Final determination of suitability of any material is the sole responsibility of the user. All materials may present unknown hazards and should be used with caution. Although certain hazards are described herein, we cannot guarantee that these are the only hazards that exist.



# SAFETY DATA SHEET

## Methane

### Section 1. Identification

<b>GHS product identifier</b>	: Methane
<b>Chemical name</b>	: methane
<b>Other means of identification</b>	: Methane or natural gas; Marsh gas; Methyl hydride; CH <sub>4</sub> ; Fire Damp;
<b>Product type</b>	: Gas.
<b>Product use</b>	: Synthetic/Analytical chemistry.
<b>Synonym</b>	: Methane or natural gas; Marsh gas; Methyl hydride; CH <sub>4</sub> ; Fire Damp;
<b>SDS #</b>	: 001033
<b>Supplier's details</b>	: Airgas USA, LLC and its affiliates 259 North Radnor-Chester Road Suite 100 Radnor, PA 19087-5283 1-610-687-5253
<b>24-hour telephone</b>	: 1-866-734-3438

### Section 2. Hazards identification

<b>OSHA/HCS status</b>	: This material is considered hazardous by the OSHA Hazard Communication Standard (29 CFR 1910.1200).
<b>Classification of the substance or mixture</b>	: FLAMMABLE GASES - Category 1 GASES UNDER PRESSURE - Compressed gas

#### GHS label elements

##### Hazard pictograms

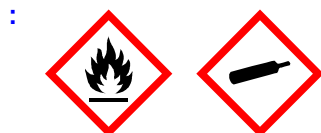

##### Signal word

: Danger

##### Hazard statements

: Extremely flammable gas.  
May form explosive mixtures with air.  
Contains gas under pressure; may explode if heated.  
May displace oxygen and cause rapid suffocation.

#### Precautionary statements

##### General

: Read and follow all Safety Data Sheets (SDS'S) before use. Read label before use. Keep out of reach of children. If medical advice is needed, have product container or label at hand. Close valve after each use and when empty. Use equipment rated for cylinder pressure. Do not open valve until connected to equipment prepared for use. Use a back flow preventative device in the piping. Use only equipment of compatible materials of construction. Approach suspected leak area with caution.

##### Prevention

: Keep away from heat, hot surfaces, sparks, open flames and other ignition sources. No smoking.

##### Response

: Leaking gas fire: Do not extinguish, unless leak can be stopped safely. Eliminate all ignition sources if safe to do so.

##### Storage

: Protect from sunlight. Store in a well-ventilated place.

##### Disposal

: Not applicable.

##### Hazards not otherwise classified

: In addition to any other important health or physical hazards, this product may displace oxygen and cause rapid suffocation.

## Section 3. Composition/information on ingredients

<b>Substance/mixture</b>	: Substance
<b>Chemical name</b>	: methane
<b>Other means of identification</b>	: Methane or natural gas; Marsh gas; Methyl hydride; CH <sub>4</sub> ; Fire Damp;
<b>Product code</b>	: 001033

### CAS number/other identifiers

**CAS number** : 74-82-8

Ingredient name	%	CAS number
methane	100	74-82-8

Any concentration shown as a range is to protect confidentiality or is due to batch variation.

**There are no additional ingredients present which, within the current knowledge of the supplier and in the concentrations applicable, are classified as hazardous to health or the environment and hence require reporting in this section.**

Occupational exposure limits, if available, are listed in Section 8.

## Section 4. First aid measures

### Description of necessary first aid measures

<b>Eye contact</b>	: Immediately flush eyes with plenty of water, occasionally lifting the upper and lower eyelids. Check for and remove any contact lenses. Continue to rinse for at least 10 minutes. Get medical attention if irritation occurs.
<b>Inhalation</b>	: Remove victim to fresh air and keep at rest in a position comfortable for breathing. If not breathing, if breathing is irregular or if respiratory arrest occurs, provide artificial respiration or oxygen by trained personnel. It may be dangerous to the person providing aid to give mouth-to-mouth resuscitation. Get medical attention if adverse health effects persist or are severe. If unconscious, place in recovery position and get medical attention immediately. Maintain an open airway. Loosen tight clothing such as a collar, tie, belt or waistband.
<b>Skin contact</b>	: Wash contaminated skin with soap and water. Remove contaminated clothing and shoes. To avoid the risk of static discharges and gas ignition, soak contaminated clothing thoroughly with water before removing it. Get medical attention if symptoms occur. Wash clothing before reuse. Clean shoes thoroughly before reuse.
<b>Ingestion</b>	: As this product is a gas, refer to the inhalation section.

### Most important symptoms/effects, acute and delayed

#### Potential acute health effects

<b>Eye contact</b>	: Contact with rapidly expanding gas may cause burns or frostbite.
<b>Inhalation</b>	: No known significant effects or critical hazards.
<b>Skin contact</b>	: Contact with rapidly expanding gas may cause burns or frostbite.
<b>Frostbite</b>	: Try to warm up the frozen tissues and seek medical attention.
<b>Ingestion</b>	: As this product is a gas, refer to the inhalation section.

#### Over-exposure signs/symptoms

<b>Eye contact</b>	: No specific data.
<b>Inhalation</b>	: No specific data.
<b>Skin contact</b>	: No specific data.
<b>Ingestion</b>	: No specific data.

### Indication of immediate medical attention and special treatment needed, if necessary

<b>Notes to physician</b>	: Treat symptomatically. Contact poison treatment specialist immediately if large quantities have been ingested or inhaled.
<b>Specific treatments</b>	: No specific treatment.

## Section 4. First aid measures

- Protection of first-aiders** : No action shall be taken involving any personal risk or without suitable training. It may be dangerous to the person providing aid to give mouth-to-mouth resuscitation.

See toxicological information (Section 11)

## Section 5. Fire-fighting measures

### Extinguishing media

- Suitable extinguishing media** : Use an extinguishing agent suitable for the surrounding fire.
- Unsuitable extinguishing media** : None known.

- Specific hazards arising from the chemical** : Contains gas under pressure. Extremely flammable gas. In a fire or if heated, a pressure increase will occur and the container may burst, with the risk of a subsequent explosion.

- Hazardous thermal decomposition products** : Decomposition products may include the following materials:  
carbon dioxide  
carbon monoxide

- Special protective actions for fire-fighters** : Promptly isolate the scene by removing all persons from the vicinity of the incident if there is a fire. No action shall be taken involving any personal risk or without suitable training. Contact supplier immediately for specialist advice. Move containers from fire area if this can be done without risk. Use water spray to keep fire-exposed containers cool. If involved in fire, shut off flow immediately if it can be done without risk. If this is impossible, withdraw from area and allow fire to burn. Fight fire from protected location or maximum possible distance. Eliminate all ignition sources if safe to do so.

- Special protective equipment for fire-fighters** : Fire-fighters should wear appropriate protective equipment and self-contained breathing apparatus (SCBA) with a full face-piece operated in positive pressure mode.

## Section 6. Accidental release measures

### Personal precautions, protective equipment and emergency procedures

- For non-emergency personnel** : Accidental releases pose a serious fire or explosion hazard. No action shall be taken involving any personal risk or without suitable training. Evacuate surrounding areas. Keep unnecessary and unprotected personnel from entering. Shut off all ignition sources. No flares, smoking or flames in hazard area. Avoid breathing gas. Provide adequate ventilation. Wear appropriate respirator when ventilation is inadequate. Put on appropriate personal protective equipment.

- For emergency responders** : If specialized clothing is required to deal with the spillage, take note of any information in Section 8 on suitable and unsuitable materials. See also the information in "For non-emergency personnel".

- Environmental precautions** : Ensure emergency procedures to deal with accidental gas releases are in place to avoid contamination of the environment. Inform the relevant authorities if the product has caused environmental pollution (sewers, waterways, soil or air).

### Methods and materials for containment and cleaning up

- Small spill** : Immediately contact emergency personnel. Stop leak if without risk. Use spark-proof tools and explosion-proof equipment.
- Large spill** : Immediately contact emergency personnel. Stop leak if without risk. Use spark-proof tools and explosion-proof equipment. Note: see Section 1 for emergency contact information and Section 13 for waste disposal.

## Section 7. Handling and storage

### Precautions for safe handling

**Protective measures** : Put on appropriate personal protective equipment (see Section 8). Contains gas under pressure. Avoid breathing gas. Use only with adequate ventilation. Wear appropriate respirator when ventilation is inadequate. Do not enter storage areas and confined spaces unless adequately ventilated. Do not puncture or incinerate container. Use equipment rated for cylinder pressure. Close valve after each use and when empty. Protect cylinders from physical damage; do not drag, roll, slide, or drop. Use a suitable hand truck for cylinder movement.

Use only non-sparking tools. Avoid contact with eyes, skin and clothing. Empty containers retain product residue and can be hazardous. Store and use away from heat, sparks, open flame or any other ignition source. Use explosion-proof electrical (ventilating, lighting and material handling) equipment.

**Advice on general occupational hygiene** : Eating, drinking and smoking should be prohibited in areas where this material is handled, stored and processed. Workers should wash hands and face before eating, drinking and smoking. Remove contaminated clothing and protective equipment before entering eating areas. See also Section 8 for additional information on hygiene measures.

**Conditions for safe storage, including any incompatibilities** : Store in accordance with local regulations. Store in a segregated and approved area. Store away from direct sunlight in a dry, cool and well-ventilated area, away from incompatible materials (see Section 10). Eliminate all ignition sources. Cylinders should be stored upright, with valve protection cap in place, and firmly secured to prevent falling or being knocked over. Cylinder temperatures should not exceed 52 °C (125 °F). Keep container tightly closed and sealed until ready for use. See Section 10 for incompatible materials before handling or use.

## Section 8. Exposure controls/personal protection

### Control parameters

#### Occupational exposure limits

Ingredient name	Exposure limits
methane	None.

**Appropriate engineering controls** : Use only with adequate ventilation. Use process enclosures, local exhaust ventilation or other engineering controls to keep worker exposure to airborne contaminants below any recommended or statutory limits. The engineering controls also need to keep gas, vapor or dust concentrations below any lower explosive limits. Use explosion-proof ventilation equipment.

**Environmental exposure controls** : Emissions from ventilation or work process equipment should be checked to ensure they comply with the requirements of environmental protection legislation. In some cases, fume scrubbers, filters or engineering modifications to the process equipment will be necessary to reduce emissions to acceptable levels.

### Individual protection measures

**Hygiene measures** : Wash hands, forearms and face thoroughly after handling chemical products, before eating, smoking and using the lavatory and at the end of the working period. Appropriate techniques should be used to remove potentially contaminated clothing. Wash contaminated clothing before reusing. Ensure that eyewash stations and safety showers are close to the workstation location.

**Eye/face protection** : Safety eyewear complying with an approved standard should be used when a risk assessment indicates this is necessary to avoid exposure to liquid splashes, mists, gases or dusts. If contact is possible, the following protection should be worn, unless the assessment indicates a higher degree of protection: safety glasses with side-shields.

#### Skin protection

## Section 8. Exposure controls/personal protection

- Hand protection** : Chemical-resistant, impervious gloves complying with an approved standard should be worn at all times when handling chemical products if a risk assessment indicates this is necessary. Considering the parameters specified by the glove manufacturer, check during use that the gloves are still retaining their protective properties. It should be noted that the time to breakthrough for any glove material may be different for different glove manufacturers. In the case of mixtures, consisting of several substances, the protection time of the gloves cannot be accurately estimated.
- Body protection** : Personal protective equipment for the body should be selected based on the task being performed and the risks involved and should be approved by a specialist before handling this product. When there is a risk of ignition from static electricity, wear anti-static protective clothing. For the greatest protection from static discharges, clothing should include anti-static overalls, boots and gloves.
- Other skin protection** : Appropriate footwear and any additional skin protection measures should be selected based on the task being performed and the risks involved and should be approved by a specialist before handling this product.
- Respiratory protection** : Based on the hazard and potential for exposure, select a respirator that meets the appropriate standard or certification. Respirators must be used according to a respiratory protection program to ensure proper fitting, training, and other important aspects of use. Respirator selection must be based on known or anticipated exposure levels, the hazards of the product and the safe working limits of the selected respirator.

## Section 9. Physical and chemical properties

### Appearance

- Physical state** : Gas. [Compressed gas.]
- Color** : Colorless.
- Odor** : Odorless.
- Odor threshold** : Not available.
- pH** : Not available.
- Melting point** : -187.6°C (-305.7°F)
- Boiling point** : -161.48°C (-258.7°F)
- Critical temperature** : -82.45°C (-116.4°F)
- Flash point** : Closed cup: -104°C (-155.2°F)
- Evaporation rate** : Not available.
- Flammability (solid, gas)** : Extremely flammable in the presence of the following materials or conditions: open flames, sparks and static discharge and oxidizing materials.
- Lower and upper explosive (flammable) limits** : Lower: 5%  
Upper: 14%
- Vapor pressure** : Not available.
- Vapor density** : 0.6 (Air = 1)
- Specific Volume (ft<sup>3</sup>/lb)** : 23.6407
- Gas Density (lb/ft<sup>3</sup>)** : 0.0423 (25°C / 77 to °F)
- Relative density** : Not applicable.
- Solubility** : Not available.
- Solubility in water** : 0.02 g/l
- Partition coefficient: n-octanol/water** : 1.09
- Auto-ignition temperature** : 537°C (998.6°F)
- Decomposition temperature** : Not available.
- Viscosity** : Not applicable.
- Flow time (ISO 2431)** : Not available.
- Molecular weight** : 16.05 g/mole
- Aerosol product**
- Heat of combustion** : -50048542 J/kg

## Section 10. Stability and reactivity

- Reactivity** : No specific test data related to reactivity available for this product or its ingredients.
- Chemical stability** : The product is stable.
- Possibility of hazardous reactions** : Under normal conditions of storage and use, hazardous reactions will not occur.
- Conditions to avoid** : Avoid all possible sources of ignition (spark or flame). Do not pressurize, cut, weld, braze, solder, drill, grind or expose containers to heat or sources of ignition.
- Incompatible materials** : Oxidizers
- Hazardous decomposition products** : Under normal conditions of storage and use, hazardous decomposition products should not be produced.
- Hazardous polymerization** : Under normal conditions of storage and use, hazardous polymerization will not occur.

## Section 11. Toxicological information

### Information on toxicological effects

#### Acute toxicity

Not available.

#### Irritation/Corrosion

Not available.

#### Sensitization

Not available.

#### Mutagenicity

Not available.

#### Carcinogenicity

Not available.

#### Reproductive toxicity

Not available.

#### Teratogenicity

Not available.

#### Specific target organ toxicity (single exposure)

Not available.

#### Specific target organ toxicity (repeated exposure)

Not available.

#### Aspiration hazard

Not available.

**Information on the likely routes of exposure** : Not available.

### Potential acute health effects

- Eye contact** : Contact with rapidly expanding gas may cause burns or frostbite.
- Inhalation** : No known significant effects or critical hazards.

## Section 11. Toxicological information

- Skin contact** : Contact with rapidly expanding gas may cause burns or frostbite.  
**Ingestion** : As this product is a gas, refer to the inhalation section.

### Symptoms related to the physical, chemical and toxicological characteristics

- Eye contact** : No specific data.  
**Inhalation** : No specific data.  
**Skin contact** : No specific data.  
**Ingestion** : No specific data.

### Delayed and immediate effects and also chronic effects from short and long term exposure

#### Short term exposure

- Potential immediate effects** : Not available.  
**Potential delayed effects** : Not available.

#### Long term exposure

- Potential immediate effects** : Not available.  
**Potential delayed effects** : Not available.

#### Potential chronic health effects

Not available.

- General** : No known significant effects or critical hazards.  
**Carcinogenicity** : No known significant effects or critical hazards.  
**Mutagenicity** : No known significant effects or critical hazards.  
**Teratogenicity** : No known significant effects or critical hazards.  
**Developmental effects** : No known significant effects or critical hazards.  
**Fertility effects** : No known significant effects or critical hazards.

### Numerical measures of toxicity

#### Acute toxicity estimates

Not available.

## Section 12. Ecological information

### Toxicity

Not available.

### Persistence and degradability

Not available.

### Bioaccumulative potential

Product/ingredient name	LogP <sub>ow</sub>	BCF	Potential
methane	1.09	-	low

### Mobility in soil

- Soil/water partition coefficient (K<sub>oc</sub>)** : Not available.





## Section 12. Ecological information

**Other adverse effects** : No known significant effects or critical hazards.

## Section 13. Disposal considerations

**Disposal methods** : The generation of waste should be avoided or minimized wherever possible. Disposal of this product, solutions and any by-products should at all times comply with the requirements of environmental protection and waste disposal legislation and any regional local authority requirements. Dispose of surplus and non-recyclable products via a licensed waste disposal contractor. Waste should not be disposed of untreated to the sewer unless fully compliant with the requirements of all authorities with jurisdiction. Empty Airgas-owned pressure vessels should be returned to Airgas. Waste packaging should be recycled. Incineration or landfill should only be considered when recycling is not feasible. This material and its container must be disposed of in a safe way. Empty containers or liners may retain some product residues. Do not puncture or incinerate container.

## Section 14. Transport information

	DOT	TDG	Mexico	IMDG	IATA
<b>UN number</b>	UN1971	UN1971	UN1971	UN1971	UN1971
<b>UN proper shipping name</b>	Methane, compressed	Methane, compressed or Methane or Natural gas, compressed (with high methane content)	Methane, compressed	Methane, compressed	Methane, compressed
<b>Transport hazard class(es)</b>	2.1 	2.1 	2.1 	2.1 	2.1 
<b>Packing group</b>	-	-	-	-	-
<b>Environmental hazards</b>	No.	No.	No.	No.	No.

“Refer to CFR 49 (or authority having jurisdiction) to determine the information required for shipment of the product.”

### Additional information

**TDG Classification** : Product classified as per the following sections of the Transportation of Dangerous Goods Regulations: 2.13-2.17 (Class 2).  
**Explosive Limit and Limited Quantity Index** 0.125  
**ERAP Index** 3000  
**Passenger Carrying Vessel Index** Forbidden  
**Passenger Carrying Road or Rail Index** Forbidden

**IATA** : **Quantity limitation** Passenger and Cargo Aircraft: Forbidden. Cargo Aircraft Only: 150 kg.

**Special precautions for user** : **Transport within user’s premises:** always transport in closed containers that are upright and secure. Ensure that persons transporting the product know what to do in the event of an accident or spillage.

**Transport in bulk according to IMO instruments** : Not available.



## Section 15. Regulatory information

**U.S. Federal regulations** : TSCA 8(a) CDR Exempt/Partial exemption: Not determined  
**Clean Air Act (CAA) 112 regulated flammable substances:** methane

**Clean Air Act Section 112 (b) Hazardous Air Pollutants (HAPs)** : Not listed

**Clean Air Act Section 602 Class I Substances** : Not listed

**Clean Air Act Section 602 Class II Substances** : Not listed

**DEA List I Chemicals (Precursor Chemicals)** : Not listed

**DEA List II Chemicals (Essential Chemicals)** : Not listed

### SARA 302/304

#### Composition/information on ingredients

No products were found.

**SARA 304 RQ** : Not applicable.

### SARA 311/312

**Classification** : Refer to Section 2: Hazards Identification of this SDS for classification of substance.

### State regulations

**Massachusetts** : This material is listed.

**New York** : This material is not listed.

**New Jersey** : This material is listed.

**Pennsylvania** : This material is listed.

### International regulations

#### Chemical Weapon Convention List Schedules I, II & III Chemicals

Not listed.

#### Montreal Protocol

Not listed.

#### Stockholm Convention on Persistent Organic Pollutants

Not listed.

#### Rotterdam Convention on Prior Informed Consent (PIC)

Not listed.

#### UNECE Aarhus Protocol on POPs and Heavy Metals

Not listed.

### Inventory list

**Australia** : This material is listed or exempted.

**Canada** : This material is listed or exempted.

**China** : This material is listed or exempted.

**Europe** : This material is listed or exempted.

**Japan** : **Japan inventory (ENCS):** This material is listed or exempted.  
**Japan inventory (ISHL):** Not determined.

**New Zealand** : This material is listed or exempted.

**Philippines** : This material is listed or exempted.

**Republic of Korea** : This material is listed or exempted.

**Taiwan** : This material is listed or exempted.

## Section 15. Regulatory information

- Thailand** : Not determined.
- Turkey** : This material is listed or exempted.
- United States** : This material is listed or exempted.
- Viet Nam** : Not determined.

## Section 16. Other information

### Hazardous Material Information System (U.S.A.)

Health	/	1
Flammability		4
Physical hazards		3

Caution: HMIS® ratings are based on a 0-4 rating scale, with 0 representing minimal hazards or risks, and 4 representing significant hazards or risks. Although HMIS® ratings and the associated label are not required on SDSs or products leaving a facility under 29 CFR 1910.1200, the preparer may choose to provide them. HMIS® ratings are to be used with a fully implemented HMIS® program. HMIS® is a registered trademark and service mark of the American Coatings Association, Inc.

The customer is responsible for determining the PPE code for this material. For more information on HMIS® Personal Protective Equipment (PPE) codes, consult the HMIS® Implementation Manual.

### National Fire Protection Association (U.S.A.)



Reprinted with permission from NFPA 704-2001, Identification of the Hazards of Materials for Emergency Response Copyright ©1997, National Fire Protection Association, Quincy, MA 02269. This reprinted material is not the complete and official position of the National Fire Protection Association, on the referenced subject which is represented only by the standard in its entirety.

Copyright ©2001, National Fire Protection Association, Quincy, MA 02269. This warning system is intended to be interpreted and applied only by properly trained individuals to identify fire, health and reactivity hazards of chemicals. The user is referred to certain limited number of chemicals with recommended classifications in NFPA 49 and NFPA 325, which would be used as a guideline only. Whether the chemicals are classified by NFPA or not, anyone using the 704 systems to classify chemicals does so at their own risk.

### Procedure used to derive the classification

Classification	Justification
FLAMMABLE GASES - Category 1 GASES UNDER PRESSURE - Compressed gas	Expert judgment According to package

### History

- Date of printing** : 11/15/2020
- Date of issue/Date of revision** : 11/15/2020
- Date of previous issue** : 3/14/2019
- Version** : 1.08

### Key to abbreviations

- : ATE = Acute Toxicity Estimate
- : BCF = Bioconcentration Factor
- : GHS = Globally Harmonized System of Classification and Labelling of Chemicals
- : IATA = International Air Transport Association
- : IBC = Intermediate Bulk Container
- : IMDG = International Maritime Dangerous Goods
- : LogPow = logarithm of the octanol/water partition coefficient
- : MARPOL = International Convention for the Prevention of Pollution From Ships, 1973 as modified by the Protocol of 1978. ("Marpol" = marine pollution)
- : UN = United Nations

## Section 16. Other information

**References** : Not available.

### Notice to reader

To the best of our knowledge, the information contained herein is accurate. However, neither the above-named supplier, nor any of its subsidiaries, assumes any liability whatsoever for the accuracy or completeness of the information contained herein.

Final determination of suitability of any material is the sole responsibility of the user. All materials may present unknown hazards and should be used with caution. Although certain hazards are described herein, we cannot guarantee that these are the only hazards that exist.

**ATTACHMENT I**

**EMISSION UNITS TABLE**

**Attachment I  
Emission Units Table  
(includes all emission units and air pollution control devices  
that will be part of this permit application review, regardless of permitting status)**

Emission Unit ID <sup>1</sup>	Emission Point ID <sup>2</sup>	Emission Unit Description	Year Installed/Modified	Design Capacity	Type <sup>3</sup> and Date of Change	Control Device <sup>4</sup>
<b>Ammonia Unit #1</b>						
1S-1	2E-1	Feed Purification	2024	6,000 MTPD NH3	New	2C-1
2S-1	2E-1	Reformer Section	2024		New	2C-1
3S-1	2E-1	ATR Section	2024		New	2C-1
4S-1	2E-1	CO Conversion Section	2024		New	2C-1
5S-1	2E-1	Nitrogen Wash Unit	2024		New	2C-1
6S-1	2E-1	CO2 Removal Section	2024		New	2C-1
7S-1	3E-1	Ammonia Loop	2024		New	3C-1
8S-1	1E-1	Startup Steam Generator	2024		New	1C-1
9S-1	1E-1	Pre-Heater	2024		New	1C-1
10S-1	1E-1	Super Heater	2024		New	1C-1
11S-1	4E-1	Startup & Emergency Generator	2024	1,000 KW	New	NA
<b>Ammonia Unit #2</b>						
1S-2	2E-2	Feed Purification	2024	6,000 MTPD NH3	New	2C-1
2S-2	2E-2	Reformer Section	2024		New	2C-1
3S-2	2E-2	ATR Section	2024		New	2C-1
4S-2	2E-2	CO Conversion Section	2024		New	2C-1
5S-2	2E-2	Nitrogen Wash Unit	2024		New	2C-1
6S-2	2E-2	CO2 Removal Section	2024		New	2C-1
7S-2	3E-2	Ammonia Loop	2024		New	3C-1
8S-2	1E-2	Startup Steam Generator	2024		New	1C-1
9S-2	1E-2	Pre-Heater	2024		New	1C-1
10S-2	1E-2	Super Heater	2024		New	1C-1
11S-2	4E-2	Startup & Emergency Generator	2024	1,000 KW	New	NA
<sup>1</sup> For Emission Units (or Sources) use the following numbering system: 1S, 2S, 3S, or other appropriate designation <sup>2</sup> For Emission Points use the following numbering system: 1E, 2E, 3E, or other appropriate designation. <sup>3</sup> New, modification, removal <sup>4</sup> For Control Devices use the following numbering system: 1C, 2C, 3C, or other appropriate designation.						

**Attachment I  
Emission Units Table  
(includes all emission units and air pollution control devices  
that will be part of this permit application review, regardless of permitting status)**

Emission Unit ID <sup>1</sup>	Emission Point ID <sup>2</sup>	Emission Unit Description	Year Installed/Modified	Design Capacity	Type <sup>3</sup> and Date of Change	Control Device <sup>4</sup>
<b>Ammonia Unit #3</b>						
1S-3	2E-3	Feed Purification	2024	6,000 MTPD NH3	New	2C-1
2S-3	2E-3	Reformer Section	2024		New	2C-1
3S-3	2E-3	ATR Section	2024		New	2C-1
4S-3	2E-3	CO Conversion Section	2024		New	2C-1
5S-3	2E-3	Nitrogen Wash Unit	2024		New	2C-1
6S-3	2E-3	CO2 Removal Section	2024		New	2C-1
7S-3	3E-3	Ammonia Loop	2024		New	3C-1
8S-3	1E-3	Startup Steam Generator	2024		New	1C-1
9S-3	1E-3	Pre-Heater	2024		New	1C-1
10S-3	1E-3	Super Heater	2024		New	1C-1
11S-3	4E-3	Startup & Emergency Generator	2024	1,000 KW	New	NA
<b>Ammonia Unit #4</b>						
1S-4	2E-4	Feed Purification	2024	+	New	2C-1
2S-4	2E-4	Reformer Section	2024		New	2C-1
3S-4	2E-4	ATR Section	2024		New	2C-1
4S-4	2E-4	CO Conversion Section	2024		New	2C-1
5S-4	2E-4	Nitrogen Wash Unit	2024		New	2C-1
6S-4	2E-4	CO2 Removal Section	2024		New	2C-1
7S-4	3E-4	Ammonia Loop	2024		New	3C-1
8S-4	1E-4	Startup Steam Generator	2024		New	1C-1
9S-4	1E-4	Pre-Heater	2024		New	1C-1
10S-4	1E-4	Super Heater	2024		New	1C-1
11S-4	4E-4	Startup & Emergency Generator	2024	1,000 KW	New	NA

<sup>1</sup> For Emission Units (or Sources) use the following numbering system: 1S, 2S, 3S, or other appropriate designation

<sup>2</sup> For Emission Points use the following numbering system: 1E, 2E, 3E, or other appropriate designation.

<sup>3</sup> New, modification, removal

<sup>4</sup> For Control Devices use the following numbering system: 1C, 2C, 3C, or other appropriate designation.

**Attachment I  
Emission Units Table  
(includes all emission units and air pollution control devices  
that will be part of this permit application review, regardless of permitting status)**

Emission Unit ID <sup>1</sup>	Emission Point ID <sup>2</sup>	Emission Unit Description	Year Installed/Modified	Design Capacity	Type <sup>3</sup> and Date of Change	Control Device <sup>4</sup>
<b>Ammonia Unit #5</b>						
1S-5	2E-5	Feed Purification	2024	6,000 MTPD NH3	New	2C-1
2S-5	2E-5	Reformer Section	2024		New	2C-1
3S-5	2E-5	ATR Section	2024		New	2C-1
4S-5	2E-5	CO Conversion Section	2024		New	2C-1
5S-5	2E-5	Nitrogen Wash Unit	2024		New	2C-1
6S-5	2E-5	CO2 Removal Section	2024		New	2C-1
7S-5	3E-5	Ammonia Loop	2024		New	3C-1
8S-5	1E-5	Startup Steam Generator	2024		New	1C-1
9S-5	1E-5	Pre-Heater	2024		New	1C-1
10S-5	1E-5	Super Heater	2024		New	1C-1
11S-5	4E-5	Startup & Emergency Generator	2024	1,000 KW	New	NA
<b>Ammonia Unit #6</b>						
1S-6	2E-6	Feed Purification	2024	6,000 MTPD NH3	New	2C-1
2S-6	2E-6	Reformer Section	2024		New	2C-1
3S-6	2E-6	ATR Section	2024		New	2C-1
4S-6	2E-6	CO Conversion Section	2024		New	2C-1
5S-6	2E-6	Nitrogen Wash Unit	2024		New	2C-1
6S-6	2E-6	CO2 Removal Section	2024		New	2C-1
7S-6	3E-6	Ammonia Loop	2024		New	3C-1
8S-6	1E-6	Startup Steam Generator	2024		New	1C-1
9S-6	1E-6	Pre-Heater	2024		New	1C-1
10S-6	1E-6	Super Heater	2024		New	1C-1
11S-6	4E-6	Startup & Emergency Generator	2024	1,000 KW	New	NA

<sup>1</sup> For Emission Units (or Sources) use the following numbering system: 1S, 2S, 3S, or other appropriate designation

<sup>2</sup> For Emission Points use the following numbering system: 1E, 2E, 3E, or other appropriate designation.

<sup>3</sup> New, modification, removal

<sup>4</sup> For Control Devices use the following numbering system: 1C, 2C, 3C, or other appropriate designation.

**ATTACHMENT J**

**EMISSION POINTS DATA**  
**SUMMARY SHEET**



**Attachment J**  
**EMISSION POINTS DATA SUMMARY SHEET**

**Table 1: Emissions Data – STEADY STATE (INCLUDES STARTUP EMISSIONS TO SCR)**

Emission Point ID No. (Must match Emission Units Table & Plot Plan)	Emission Point Type <sup>1</sup>	Emission Unit Vented Through This Point (Must match Emission Units Table & Plot Plan)		Air Pollution Control Device (Must match Emission Units Table & Plot Plan)		Vent Time for Emission Unit (chemical processes only)		All Regulated Pollutants - Chemical Name/CAS <sup>3</sup>  (Speciate VOCs & HAPS)	Maximum Potential Uncontrolled Emissions <sup>4</sup>		Maximum Potential Controlled Emissions <sup>5</sup>		Emission Form or Phase  (At exit conditions, Solid, Liquid or Gas/Vapor)	Est. Method Used <sup>6</sup>	Emission Concentration <sup>7</sup> (ppmv or mg/m <sup>4</sup> )
		ID No.	Source	ID No.	Device Type	Short Term <sup>2</sup>	Max (hr/yr)		lb/hr	ton/yr	lb/hr	ton/yr			
1E-1 to 6	Vertical Stack	8S-1 to 6	Startup Steam Generator	1C	SCR Units	NA	NA	NO <sub>x</sub>	14.50	0.09	1.45	0.01	Gas	EE	NA
		9S-1 to 6	Pre-Heater H201	1C	SCR Units	NA	NA	PM	0.01	0.01	0.01	0.01	Solids and Gas	EE	NA
								PM10	0.01	0.01	0.01				
								PM2.5	0.01	0.01	0.01				
								CO	0.04	0.01	0.04				
								CO2	20.1	204.50	20.1				
								SO2	0.01	0.01	0.01				
								CH4	0.01	0.01	0.01				
								VOC	0.01	0.01	0.01				
		NO <sub>x</sub>	44.47	188.79	0.45										
		10S-1 to 6	Super Heater H202	1C	SCR Units	NA	NA	PM	0.01	0.01	0.01	0.01	Solids and Gas	EE	NA
								PM10	0.01	0.01	0.01				
PM2.5	0.01							0.01	0.01						
CO	0.01							0.15	0.01						
CO2	2.01							204.50	2.01						
SO2	0.01							0.01	0.01						
CH4	0.01	0.01	0.01												
VOC	0.01	0.01	0.01												
NO <sub>x</sub>	112.62	478.44	1.14												

The EMISSION POINTS DATA SUMMARY SHEET provides a summation of emissions by emission unit. Note that uncaptured process emission unit emissions are not typically considered to be fugitive and must be accounted for on the appropriate EMISSIONS UNIT DATA SHEET and on the EMISSION POINTS DATA SUMMARY SHEET. Please note that total emissions from the source are equal to all vented emissions, all fugitive emissions, plus all other emissions (e.g. uncaptured emissions). Please complete the FUGITIVE EMISSIONS DATA SUMMARY SHEET for fugitive emission activities.

<sup>1</sup> Please add descriptors such as upward vertical stack, downward vertical stack, horizontal stack, relief vent, rain cap, etc.

<sup>2</sup> Indicate by "C" if venting is continuous. Otherwise, specify the average short-term venting rate with units, for intermittent venting (ie., 15 min/hr). Indicate as many rates as needed to clarify frequency of venting (e.g., 5 min/day, 2 days/wk).

<sup>3</sup> List all regulated air pollutants. Speciate VOCs, including all HAPs. Follow chemical name with Chemical Abstracts Service (CAS) number. **LIST** Acids, CO, CS<sub>2</sub>, VOCs, H<sub>2</sub>S, Inorganics, Lead, Organics, O<sub>3</sub>, NO, NO<sub>2</sub>, SO<sub>2</sub>, SO<sub>3</sub>, all applicable Greenhouse Gases (including CO<sub>2</sub> and methane), etc. **DO NOT LIST** H<sub>2</sub>, H<sub>2</sub>O, N<sub>2</sub>, O<sub>2</sub>, and Noble Gases.

<sup>4</sup> Give maximum potential emission rate with no control equipment operating. If emissions occur for less than 1 hr, then record emissions per batch in minutes (e.g. 5 lb VOC/20 minute batch).

<sup>5</sup> Give maximum potential emission rate with proposed control equipment operating. If emissions occur for less than 1 hr, then record emissions per batch in minutes (e.g. 5 lb VOC/20 minute batch).

<sup>6</sup> Indicate method used to determine emission rate as follows: MB = material balance; ST = stack test (give date of test); EE = engineering estimate; O = other (specify).

<sup>7</sup> Provide for all pollutant emissions. Typically, the units of parts per million by volume (ppmv) are used. If the emission is a mineral acid (sulfuric, nitric, hydrochloric or phosphoric) use units of milligram per dry cubic meter (mg/m<sup>3</sup>) at standard conditions (68 °F and 29.92 inches Hg) (see 45CSR7). If the pollutant is SO<sub>2</sub>, use units of ppmv (See 45CSR10).

**Attachment J**  
**EMISSION POINTS DATA SUMMARY SHEET**

Table 1: Emissions Data – 2E Startup Emissions

Emission Point ID No. (Must match Emission Units Table & Plot Plan)	Emission Point Type <sup>1</sup>	Emission Unit Vented Through This Point (Must match Emission Units Table & Plot Plan)		Air Pollution Control Device (Must match Emission Units Table & Plot Plan)		Vent Time for Emission Unit (chemical processes only)		All Regulated Pollutants - Chemical Name/CAS <sup>3</sup>  (Speciate VOCs & HAPS)	Maximum Potential Uncontrolled Emissions <sup>4</sup>		Maximum Potential Controlled Emissions <sup>5</sup>		Emission Form or Phase  (At exit conditions, Solid, Liquid or Gas/Vapor)	Est. Method Used <sup>6</sup>	Emission Concentration <sup>7</sup> (ppmv or mg/m <sup>4</sup> )
		ID No.	Source	ID No.	Device Type	Short Term <sup>2</sup>	Max (hr/yr)		lb/hr	ton/yr	lb/hr	ton/yr			
2E-1 to 6	Vertical Flare	1S, 2S, 3S, 4S, 5S, and 6S	Feed Purification, Reformer Section, ATR Section, CO Conversion Section, Nitrogen Wash Unit, and CO2 Removal Section	2C	Flare	NA	NA	Hours 0-30					Gas	EE	NA
								CH4	120,995.64	1,814.94	604.98	9.08			
								CO2	581,909.11	8,728.64	2,909.55	43.65			
								NO <sub>x</sub>	--	--	337.76	5.07			
								Hours 30-36							
								CH4	9,874.23	29.63	49.37	0.15			
								CO	54,081.48	162.25	270.41	0.82			
								CO2	302.47	0.91	1.51	0.01			
NO <sub>x</sub>	--	--	337.76	1.02											

The EMISSION POINTS DATA SUMMARY SHEET provides a summation of emissions by emission unit. Note that uncaptured process emission unit emissions are not typically considered to be fugitive and must be accounted for on the appropriate EMISSIONS UNIT DATA SHEET and on the EMISSION POINTS DATA SUMMARY SHEET. Please note that total emissions from the source are equal to all vented emissions, all fugitive emissions, plus all other emissions (e.g. uncaptured emissions). Please complete the FUGITIVE EMISSIONS DATA SUMMARY SHEET for fugitive emission activities.

<sup>1</sup> Please add descriptors such as upward vertical stack, downward vertical stack, horizontal stack, relief vent, rain cap, etc.

<sup>2</sup> Indicate by "C" if venting is continuous. Otherwise, specify the average short-term venting rate with units, for intermittent venting (ie., 15 min/hr). Indicate as many rates as needed to clarify frequency of venting (e.g., 5 min/day, 2 days/wk).

<sup>3</sup> List all regulated air pollutants. Speciate VOCs, including all HAPs. Follow chemical name with Chemical Abstracts Service (CAS) number. **LIST** Acids, CO, CS<sub>2</sub>, VOCs, H<sub>2</sub>S, Inorganics, Lead, Organics, O<sub>3</sub>, NO, NO<sub>2</sub>, SO<sub>2</sub>, SO<sub>3</sub>, all applicable Greenhouse Gases (including CO<sub>2</sub> and methane), etc. **DO NOT LIST** H<sub>2</sub>, H<sub>2</sub>O, N<sub>2</sub>, O<sub>2</sub>, and Noble Gases.

<sup>4</sup> Give maximum potential emission rate with no control equipment operating. If emissions occur for less than 1 hr, then record emissions per batch in minutes (e.g. 5 lb VOC/20 minute batch).

<sup>5</sup> Give maximum potential emission rate with proposed control equipment operating. If emissions occur for less than 1 hr, then record emissions per batch in minutes (e.g. 5 lb VOC/20 minute batch).

<sup>6</sup> Indicate method used to determine emission rate as follows: MB = material balance; ST = stack test (give date of test); EE = engineering estimate; O = other (specify).

<sup>7</sup> Provide for all pollutant emissions. Typically, the units of parts per million by volume (ppmv) are used. If the emission is a mineral acid (sulfuric, nitric, hydrochloric or phosphoric) use units of milligram per dry cubic meter (mg/m<sup>3</sup>) at standard conditions (68 °F and 29.92 inches Hg) (see 45CSR7). If the pollutant is SO<sub>2</sub>, use units of ppmv (See 45CSR10).

**Attachment J**  
**EMISSION POINTS DATA SUMMARY SHEET**

Table 1: Emissions Data – 2E Shutdown Emissions

Emission Point ID No. (Must match Emission Units Table & Plot Plan)	Emission Point Type <sup>1</sup>	Emission Unit Vented Through This Point (Must match Emission Units Table & Plot Plan)		Air Pollution Control Device (Must match Emission Units Table & Plot Plan)		Vent Time for Emission Unit (chemical processes only)		All Regulated Pollutants - Chemical Name/CAS <sup>3</sup>  (Speciate VOCs & HAPS)	Maximum Potential Uncontrolled Emissions <sup>4</sup>		Maximum Potential Controlled Emissions <sup>5</sup>		Emission Form or Phase  (At exit conditions, Solid, Liquid or Gas/Vapor)	Est. Method Used <sup>6</sup>	Emission Concentration <sup>7</sup> (ppmv or mg/m <sup>4</sup> )
		ID No.	Source	ID No.	Device Type	Short Term <sup>2</sup>	Max (hr/yr)		lb/hr	ton/yr	lb/hr	ton/yr			
2E-1 to 6	Vertical Flare	1S, 2S, 3S, 4S, 5S, and 6S	Feed Purification, Reformer Section, ATR Section, CO Conversion Section, Nitrogen Wash Unit, and CO2 Removal Section	2C	Flare	NA	NA	CH4 CO2 NH3 NO <sub>x</sub>	130,869.87 582,211.59 533.28 --	313.58 1,484.02 0.01 --	654.35 2,911.06 72.67 337.76	1.57 7.42 1.36 1.04	Gas	EE	NA

The EMISSION POINTS DATA SUMMARY SHEET provides a summation of emissions by emission unit. Note that uncaptured process emission unit emissions are not typically considered to be fugitive and must be accounted for on the appropriate EMISSIONS UNIT DATA SHEET and on the EMISSION POINTS DATA SUMMARY SHEET. Please note that total emissions from the source are equal to all vented emissions, all fugitive emissions, plus all other emissions (e.g. uncaptured emissions). Please complete the FUGITIVE EMISSIONS DATA SUMMARY SHEET for fugitive emission activities.

<sup>1</sup> Please add descriptors such as upward vertical stack, downward vertical stack, horizontal stack, relief vent, rain cap, etc.

<sup>2</sup> Indicate by "C" if venting is continuous. Otherwise, specify the average short-term venting rate with units, for intermittent venting (ie., 15 min/hr). Indicate as many rates as needed to clarify frequency of venting (e.g., 5 min/day, 2 days/wk).

<sup>3</sup> List all regulated air pollutants. Speciate VOCs, including all HAPs. Follow chemical name with Chemical Abstracts Service (CAS) number. **LIST** Acids, CO, CS<sub>2</sub>, VOCs, H<sub>2</sub>S, Inorganics, Lead, Organics, O<sub>3</sub>, NO, NO<sub>2</sub>, SO<sub>2</sub>, SO<sub>3</sub>, all applicable Greenhouse Gases (including CO<sub>2</sub> and methane), etc. **DO NOT LIST** H<sub>2</sub>, H<sub>2</sub>O, N<sub>2</sub>, O<sub>2</sub>, and Noble Gases.

<sup>4</sup> Give maximum potential emission rate with no control equipment operating. If emissions occur for less than 1 hr, then record emissions per batch in minutes (e.g. 5 lb VOC/20 minute batch).

<sup>5</sup> Give maximum potential emission rate with proposed control equipment operating. If emissions occur for less than 1 hr, then record emissions per batch in minutes (e.g. 5 lb VOC/20 minute batch).

<sup>6</sup> Indicate method used to determine emission rate as follows: MB = material balance; ST = stack test (give date of test); EE = engineering estimate; O = other (specify).

<sup>7</sup> Provide for all pollutant emissions. Typically, the units of parts per million by volume (ppmv) are used. If the emission is a mineral acid (sulfuric, nitric, hydrochloric or phosphoric) use units of milligram per dry cubic meter (mg/m<sup>3</sup>) at standard conditions (68 °F and 29.92 inches Hg) (see 45CSR7). If the pollutant is SO<sub>2</sub>, use units of ppmv (See 45CSR10).

**Attachment J**  
**EMISSION POINTS DATA SUMMARY SHEET**

Table 1: Emissions Data – 2E Steady State Emissions

Emission Point ID No. (Must match Emission Units Table & Plot Plan)	Emission Point Type <sup>1</sup>	Emission Unit Vented Through This Point (Must match Emission Units Table & Plot Plan)		Air Pollution Control Device (Must match Emission Units Table & Plot Plan)		Vent Time for Emission Unit (chemical processes only)		All Regulated Pollutants - Chemical Name/CAS <sup>3</sup>  (Speciate VOCs & HAPS)	Maximum Potential Uncontrolled Emissions <sup>4</sup>		Maximum Potential Controlled Emissions <sup>5</sup>		Emission Form or Phase  (At exit conditions, Solid, Liquid or Gas/Vapor)	Est. Method Used <sup>6</sup>	Emission Concentration <sup>7</sup> (ppmv or mg/m <sup>4</sup> )
		ID No.	Source	ID No.	Device Type	Short Term <sup>2</sup>	Max (hr/yr)		lb/hr	ton/yr	lb/hr	ton/yr			
2E-1 to 6	Vertical Flare	1S, 2S, 3S, 4S, 5S, and 6S	Feed Purification, Reformer Section, ATR Section, CO Conversion Section, Nitrogen Wash Unit, and CO2 Removal Section	2C	Flare	NA	NA	CH4 CO CO2 NO <sub>x</sub>	130,869.87 54,081.48 582,211.59 --	1,844.57 162.25 8,729.55 --	654.35 270.41 2,911.06 657.51	9.23 0.82 43.66 6.09	Gas	EE	NA
Note: Steady state operations do not have venting to flare from the process. Emissions presented here are total flaring equal to one startup and continued flare operation for emergency releases.															

The EMISSION POINTS DATA SUMMARY SHEET provides a summation of emissions by emission unit. Note that uncaptured process emission unit emissions are not typically considered to be fugitive and must be accounted for on the appropriate EMISSIONS UNIT DATA SHEET and on the EMISSION POINTS DATA SUMMARY SHEET. Please note that total emissions from the source are equal to all vented emissions, all fugitive emissions, plus all other emissions (e.g. uncaptured emissions). Please complete the FUGITIVE EMISSIONS DATA SUMMARY SHEET for fugitive emission activities.

<sup>1</sup> Please add descriptors such as upward vertical stack, downward vertical stack, horizontal stack, relief vent, rain cap, etc.

<sup>2</sup> Indicate by "C" if venting is continuous. Otherwise, specify the average short-term venting rate with units, for intermittent venting (ie., 15 min/hr). Indicate as many rates as needed to clarify frequency of venting (e.g., 5 min/day, 2 days/wk).

<sup>3</sup> List all regulated air pollutants. Speciate VOCs, including all HAPs. Follow chemical name with Chemical Abstracts Service (CAS) number. **LIST** Acids, CO, CS<sub>2</sub>, VOCs, H<sub>2</sub>S, Inorganics, Lead, Organics, O<sub>3</sub>, NO, NO<sub>2</sub>, SO<sub>2</sub>, SO<sub>3</sub>, all applicable Greenhouse Gases (including CO<sub>2</sub> and methane), etc. **DO NOT LIST** H<sub>2</sub>, H<sub>2</sub>O, N<sub>2</sub>, O<sub>2</sub>, and Noble Gases.

<sup>4</sup> Give maximum potential emission rate with no control equipment operating. If emissions occur for less than 1 hr, then record emissions per batch in minutes (e.g. 5 lb VOC/20 minute batch).

<sup>5</sup> Give maximum potential emission rate with proposed control equipment operating. If emissions occur for less than 1 hr, then record emissions per batch in minutes (e.g. 5 lb VOC/20 minute batch).

<sup>6</sup> Indicate method used to determine emission rate as follows: MB = material balance; ST = stack test (give date of test); EE = engineering estimate; O = other (specify).

<sup>7</sup> Provide for all pollutant emissions. Typically, the units of parts per million by volume (ppmv) are used. If the emission is a mineral acid (sulfuric, nitric, hydrochloric or phosphoric) use units of milligram per dry cubic meter (mg/m<sup>3</sup>) at standard conditions (68 °F and 29.92 inches Hg) (see 45CSR7). If the pollutant is SO<sub>2</sub>, use units of ppmv (See 45CSR10).

## Attachment J

### EMISSION POINTS DATA SUMMARY SHEET

Table 1: Emissions Data – 3E Startup Emissions

Emission Point ID No. <i>(Must match Emission Units Table &amp; Plot Plan)</i>	Emission Point Type <sup>1</sup>	Emission Unit Vented Through This Point <i>(Must match Emission Units Table &amp; Plot Plan)</i>		Air Pollution Control Device <i>(Must match Emission Units Table &amp; Plot Plan)</i>		Vent Time for Emission Unit <i>(chemical processes only)</i>		All Regulated Pollutants - Chemical Name/CAS <sup>3</sup>  <i>(Speciate VOCs &amp; HAPS)</i>	Maximum Potential Uncontrolled Emissions <sup>4</sup>		Maximum Potential Controlled Emissions <sup>5</sup>		Emission Form or Phase  <i>(At exit conditions, Solid, Liquid or Gas/Vapor)</i>	Est. Method Used <sup>6</sup>	Emission Concentration <sup>7</sup> <i>(ppmv or mg/m<sup>4</sup>)</i>
		ID No.	Source	ID No.	Device Type	Short Term <sup>2</sup>	Max (hr/yr)		lb/hr	ton/yr	lb/hr	ton/yr			
3E-1 to 6	Vertical Flare	7S	Ammonia Loop	3C	Flare	NA	NA	NH3 NO <sub>x</sub>	87.58 --	0.26 --	0.44 154.56	0.01 0.46	Gas	EE	NA

The EMISSION POINTS DATA SUMMARY SHEET provides a summation of emissions by emission unit. Note that uncaptured process emission unit emissions are not typically considered to be fugitive and must be accounted for on the appropriate EMISSIONS UNIT DATA SHEET and on the EMISSION POINTS DATA SUMMARY SHEET. Please note that total emissions from the source are equal to all vented emissions, all fugitive emissions, plus all other emissions (e.g. uncaptured emissions). Please complete the FUGITIVE EMISSIONS DATA SUMMARY SHEET for fugitive emission activities.

<sup>1</sup> Please add descriptors such as upward vertical stack, downward vertical stack, horizontal stack, relief vent, rain cap, etc.

<sup>2</sup> Indicate by "C" if venting is continuous. Otherwise, specify the average short-term venting rate with units, for intermittent venting (ie., 15 min/hr). Indicate as many rates as needed to clarify frequency of venting (e.g., 5 min/day, 2 days/wk).

<sup>3</sup> List all regulated air pollutants. Speciate VOCs, including all HAPs. Follow chemical name with Chemical Abstracts Service (CAS) number. **LIST** Acids, CO, CS<sub>2</sub>, VOCs, H<sub>2</sub>S, Inorganics, Lead, Organics, O<sub>3</sub>, NO, NO<sub>2</sub>, SO<sub>2</sub>, SO<sub>3</sub>, all applicable Greenhouse Gases (including CO<sub>2</sub> and methane), etc. **DO NOT LIST** H<sub>2</sub>, H<sub>2</sub>O, N<sub>2</sub>, O<sub>2</sub>, and Noble Gases.

<sup>4</sup> Give maximum potential emission rate with no control equipment operating. If emissions occur for less than 1 hr, then record emissions per batch in minutes (e.g. 5 lb VOC/20 minute batch).

<sup>5</sup> Give maximum potential emission rate with proposed control equipment operating. If emissions occur for less than 1 hr, then record emissions per batch in minutes (e.g. 5 lb VOC/20 minute batch).

<sup>6</sup> Indicate method used to determine emission rate as follows: MB = material balance; ST = stack test (give date of test); EE = engineering estimate; O = other (specify).

<sup>7</sup> Provide for all pollutant emissions. Typically, the units of parts per million by volume (ppmv) are used. If the emission is a mineral acid (sulfuric, nitric, hydrochloric or phosphoric) use units of milligram per dry cubic meter (mg/m<sup>3</sup>) at standard conditions (68 °F and 29.92 inches Hg) (see 45CSR7). If the pollutant is SO<sub>2</sub>, use units of ppmv (See 45CSR10).

## Attachment J

### EMISSION POINTS DATA SUMMARY SHEET

Table 1: Emissions Data – 3E Shutdown Emissions

Emission Point ID No. (Must match Emission Units Table & Plot Plan)	Emission Point Type <sup>1</sup>	Emission Unit Vented Through This Point (Must match Emission Units Table & Plot Plan)		Air Pollution Control Device (Must match Emission Units Table & Plot Plan)		Vent Time for Emission Unit (chemical processes only)		All Regulated Pollutants - Chemical Name/CAS <sup>3</sup>  (Speciate VOCs & HAPS)	Maximum Potential Uncontrolled Emissions <sup>4</sup>		Maximum Potential Controlled Emissions <sup>5</sup>		Emission Form or Phase  (At exit conditions, Solid, Liquid or Gas/Vapor)	Est. Method Used <sup>6</sup>	Emission Concentration <sup>7</sup> (ppmv or mg/m <sup>4</sup> )
		ID No.	Source	ID No.	Device Type	Short Term <sup>2</sup>	Max (hr/yr)		lb/hr	ton/yr	lb/hr	ton/yr			
3E-1 to 6	Vertical Flare	7S	Ammonia Loop	3C	Flare	NA	NA	NH3 NO <sub>x</sub>	87.43 --	0.04 --	0.44 154.56	0.01 0.08	Gas	EE	NA

The EMISSION POINTS DATA SUMMARY SHEET provides a summation of emissions by emission unit. Note that uncaptured process emission unit emissions are not typically considered to be fugitive and must be accounted for on the appropriate EMISSIONS UNIT DATA SHEET and on the EMISSION POINTS DATA SUMMARY SHEET. Please note that total emissions from the source are equal to all vented emissions, all fugitive emissions, plus all other emissions (e.g. uncaptured emissions). Please complete the FUGITIVE EMISSIONS DATA SUMMARY SHEET for fugitive emission activities.

<sup>1</sup> Please add descriptors such as upward vertical stack, downward vertical stack, horizontal stack, relief vent, rain cap, etc.

<sup>2</sup> Indicate by "C" if venting is continuous. Otherwise, specify the average short-term venting rate with units, for intermittent venting (ie., 15 min/hr). Indicate as many rates as needed to clarify frequency of venting (e.g., 5 min/day, 2 days/wk).

<sup>3</sup> List all regulated air pollutants. Speciate VOCs, including all HAPs. Follow chemical name with Chemical Abstracts Service (CAS) number. **LIST** Acids, CO, CS<sub>2</sub>, VOCs, H<sub>2</sub>S, Inorganics, Lead, Organics, O<sub>3</sub>, NO, NO<sub>2</sub>, SO<sub>2</sub>, SO<sub>3</sub>, all applicable Greenhouse Gases (including CO<sub>2</sub> and methane), etc. **DO NOT LIST** H<sub>2</sub>, H<sub>2</sub>O, N<sub>2</sub>, O<sub>2</sub>, and Noble Gases.

<sup>4</sup> Give maximum potential emission rate with no control equipment operating. If emissions occur for less than 1 hr, then record emissions per batch in minutes (e.g. 5 lb VOC/20 minute batch).

<sup>5</sup> Give maximum potential emission rate with proposed control equipment operating. If emissions occur for less than 1 hr, then record emissions per batch in minutes (e.g. 5 lb VOC/20 minute batch).

<sup>6</sup> Indicate method used to determine emission rate as follows: MB = material balance; ST = stack test (give date of test); EE = engineering estimate; O = other (specify).

<sup>7</sup> Provide for all pollutant emissions. Typically, the units of parts per million by volume (ppmv) are used. If the emission is a mineral acid (sulfuric, nitric, hydrochloric or phosphoric) use units of milligram per dry cubic meter (mg/m<sup>3</sup>) at standard conditions (68 °F and 29.92 inches Hg) (see 45CSR7). If the pollutant is SO<sub>2</sub>, use units of ppmv (See 45CSR10).

## Attachment J

### EMISSION POINTS DATA SUMMARY SHEET

Table 1: Emissions Data – 3E Steady State Emissions

Emission Point ID No. <i>(Must match Emission Units Table &amp; Plot Plan)</i>	Emission Point Type <sup>1</sup>	Emission Unit Vented Through This Point <i>(Must match Emission Units Table &amp; Plot Plan)</i>		Air Pollution Control Device <i>(Must match Emission Units Table &amp; Plot Plan)</i>		Vent Time for Emission Unit <i>(chemical processes only)</i>		All Regulated Pollutants - Chemical Name/CAS <sup>3</sup>  <i>(Speciate VOCs &amp; HAPS)</i>	Maximum Potential Uncontrolled Emissions <sup>4</sup>		Maximum Potential Controlled Emissions <sup>5</sup>		Emission Form or Phase  <i>(At exit conditions, Solid, Liquid or Gas/Vapor)</i>	Est. Method Used <sup>6</sup>	Emission Concentration <sup>7</sup> <i>(ppmv or mg/m<sup>4</sup>)</i>
		ID No.	Source	ID No.	Device Type	Short Term <sup>2</sup>	Max (hr/yr)		lb/hr	ton/yr	lb/hr	ton/yr			
3E-1 to 6	Vertical Flare	7S	Ammonia Loop	3C	Flare	NA	NA	NH3 NO <sub>x</sub>	87.58 --	0.26 --	0.44 154.56	0.01 0.45	Gas	EE	NA

The EMISSION POINTS DATA SUMMARY SHEET provides a summation of emissions by emission unit. Note that uncaptured process emission unit emissions are not typically considered to be fugitive and must be accounted for on the appropriate EMISSIONS UNIT DATA SHEET and on the EMISSION POINTS DATA SUMMARY SHEET. Please note that total emissions from the source are equal to all vented emissions, all fugitive emissions, plus all other emissions (e.g. uncaptured emissions). Please complete the FUGITIVE EMISSIONS DATA SUMMARY SHEET for fugitive emission activities.

<sup>1</sup> Please add descriptors such as upward vertical stack, downward vertical stack, horizontal stack, relief vent, rain cap, etc.

<sup>2</sup> Indicate by "C" if venting is continuous. Otherwise, specify the average short-term venting rate with units, for intermittent venting (ie., 15 min/hr). Indicate as many rates as needed to clarify frequency of venting (e.g., 5 min/day, 2 days/wk).

<sup>3</sup> List all regulated air pollutants. Speciate VOCs, including all HAPs. Follow chemical name with Chemical Abstracts Service (CAS) number. **LIST** Acids, CO, CS<sub>2</sub>, VOCs, H<sub>2</sub>S, Inorganics, Lead, Organics, O<sub>3</sub>, NO, NO<sub>2</sub>, SO<sub>2</sub>, SO<sub>3</sub>, all applicable Greenhouse Gases (including CO<sub>2</sub> and methane), etc. **DO NOT LIST** H<sub>2</sub>, H<sub>2</sub>O, N<sub>2</sub>, O<sub>2</sub>, and Noble Gases.

<sup>4</sup> Give maximum potential emission rate with no control equipment operating. If emissions occur for less than 1 hr, then record emissions per batch in minutes (e.g. 5 lb VOC/20 minute batch).

<sup>5</sup> Give maximum potential emission rate with proposed control equipment operating. If emissions occur for less than 1 hr, then record emissions per batch in minutes (e.g. 5 lb VOC/20 minute batch).

<sup>6</sup> Indicate method used to determine emission rate as follows: MB = material balance; ST = stack test (give date of test); EE = engineering estimate; O = other (specify).

<sup>7</sup> Provide for all pollutant emissions. Typically, the units of parts per million by volume (ppmv) are used. If the emission is a mineral acid (sulfuric, nitric, hydrochloric or phosphoric) use units of milligram per dry cubic meter (mg/m<sup>3</sup>) at standard conditions (68 °F and 29.92 inches Hg) (see 45CSR7). If the pollutant is SO<sub>2</sub>, use units of ppmv (See 45CSR10).

**Attachment J**  
**EMISSION POINTS DATA SUMMARY SHEET**

Table 1: Emissions Data – 4E Startup Emissions

Emission Point ID No. (Must match Emission Units Table & Plot Plan)	Emission Point Type <sup>1</sup>	Emission Unit Vented Through This Point (Must match Emission Units Table & Plot Plan)		Air Pollution Control Device (Must match Emission Units Table & Plot Plan)		Vent Time for Emission Unit (chemical processes only)		All Regulated Pollutants - Chemical Name/CAS <sup>3</sup>  (Speciate VOCs & HAPS)	Maximum Potential Uncontrolled Emissions <sup>4</sup>		Maximum Potential Controlled Emissions <sup>5</sup>		Emission Form or Phase  (At exit conditions, Solid, Liquid or Gas/Vapor)	Est. Method Used <sup>6</sup>	Emission Concentration <sup>7</sup> (ppmv or mg/m <sup>4</sup> )
		ID No.	Source	ID No.	Device Type	Short Term <sup>2</sup>	Max (hr/yr)		lb/hr	ton/yr	lb/hr	ton/yr			
4E-1 to 6	Vertical	11S-1 to 6	Startup & Emergency Generator	NA	NA	NA	NA	NO <sub>x</sub> CO CO <sub>2</sub> SO <sub>2</sub> CH <sub>4</sub> VOC PM/PM10/PM2.5	31.22 0.38 1,083.50 0.01 14.28 0.12 0.01	1.57 0.02 54.18 0.01 0.72 0.01 0.03	31.22 0.38 1,083.50 0.01 14.28 0.12 0.01	1.57 0.02 54.18 0.01 0.72 0.01 0.03			

The EMISSION POINTS DATA SUMMARY SHEET provides a summation of emissions by emission unit. Note that uncaptured process emission unit emissions are not typically considered to be fugitive and must be accounted for on the appropriate EMISSIONS UNIT DATA SHEET and on the EMISSION POINTS DATA SUMMARY SHEET. Please note that total emissions from the source are equal to all vented emissions, all fugitive emissions, plus all other emissions (e.g. uncaptured emissions). Please complete the FUGITIVE EMISSIONS DATA SUMMARY SHEET for fugitive emission activities.

<sup>1</sup> Please add descriptors such as upward vertical stack, downward vertical stack, horizontal stack, relief vent, rain cap, etc.

<sup>2</sup> Indicate by "C" if venting is continuous. Otherwise, specify the average short-term venting rate with units, for intermittent venting (ie., 15 min/hr). Indicate as many rates as needed to clarify frequency of venting (e.g., 5 min/day, 2 days/wk).

<sup>3</sup> List all regulated air pollutants. Speciate VOCs, including all HAPs. Follow chemical name with Chemical Abstracts Service (CAS) number. **LIST** Acids, CO, CS<sub>2</sub>, VOCs, H<sub>2</sub>S, Inorganics, Lead, Organics, O<sub>3</sub>, NO, NO<sub>2</sub>, SO<sub>2</sub>, SO<sub>3</sub>, all applicable Greenhouse Gases (including CO<sub>2</sub> and methane), etc. **DO NOT LIST** H<sub>2</sub>, H<sub>2</sub>O, N<sub>2</sub>, O<sub>2</sub>, and Noble Gases.

<sup>4</sup> Give maximum potential emission rate with no control equipment operating. If emissions occur for less than 1 hr, then record emissions per batch in minutes (e.g. 5 lb VOC/20 minute batch).

<sup>5</sup> Give maximum potential emission rate with proposed control equipment operating. If emissions occur for less than 1 hr, then record emissions per batch in minutes (e.g. 5 lb VOC/20 minute batch).

<sup>6</sup> Indicate method used to determine emission rate as follows: MB = material balance; ST = stack test (give date of test); EE = engineering estimate; O = other (specify).

<sup>7</sup> Provide for all pollutant emissions. Typically, the units of parts per million by volume (ppmv) are used. If the emission is a mineral acid (sulfuric, nitric, hydrochloric or phosphoric) use units of milligram per dry cubic meter (mg/m<sup>3</sup>) at standard conditions (68 °F and 29.92 inches Hg) (see 45CSR7). If the pollutant is SO<sub>2</sub>, use units of ppmv (See 45CSR10).



**ATTACHMENT K**

**FUGITIVE EMISSIONS DATA**  
**SUMMARY SHEET**

## FUGITIVE EMISSIONS DATA SUMMARY SHEET

The FUGITIVE EMISSIONS SUMMARY SHEET provides a summation of fugitive emissions. Fugitive emissions are those emissions, which could not reasonably pass through a stack, chimney, vent or other functionally equivalent opening. Note that uncaptured process emissions are not typically considered to be fugitive, and must be accounted for on the appropriate EMISSIONS UNIT DATA SHEET and on the EMISSION POINTS DATA SUMMARY SHEET.

Please note that total emissions from the source are equal to all vented emissions, all fugitive emissions, plus all other emissions (e.g. uncaptured emissions).

APPLICATION FORMS CHECKLIST - FUGITIVE EMISSIONS
<p>1.) Will there be haul road activities?</p> <p><input type="checkbox"/> Yes      <input checked="" type="checkbox"/> No</p> <p><input type="checkbox"/> If YES, then complete the HAUL ROAD EMISSIONS UNIT DATA SHEET.</p>
<p>2.) Will there be Storage Piles?</p> <p><input type="checkbox"/> Yes      <input checked="" type="checkbox"/> No</p> <p><input type="checkbox"/> If YES, complete Table 1 of the NONMETALLIC MINERALS PROCESSING EMISSIONS UNIT DATA SHEET.</p>
<p>3.) Will there be Liquid Loading/Unloading Operations?</p> <p><input type="checkbox"/> Yes      <input checked="" type="checkbox"/> No</p> <p><input type="checkbox"/> If YES, complete the BULK LIQUID TRANSFER OPERATIONS EMISSIONS UNIT DATA SHEET.</p>
<p>4.) Will there be emissions of air pollutants from Wastewater Treatment Evaporation?</p> <p><input type="checkbox"/> Yes      <input checked="" type="checkbox"/> No</p> <p><input type="checkbox"/> If YES, complete the GENERAL EMISSIONS UNIT DATA SHEET.</p>
<p>5.) Will there be Equipment Leaks (e.g. leaks from pumps, compressors, in-line process valves, pressure relief devices, open-ended valves, sampling connections, flanges, agitators, cooling towers, etc.)?</p> <p><input checked="" type="checkbox"/> Yes      <input type="checkbox"/> No    Leak Source Count is in Attachment N.</p> <p><input type="checkbox"/> If YES, complete the LEAK SOURCE DATA SHEET section of the CHEMICAL PROCESSES EMISSIONS UNIT DATA SHEET.</p>
<p>6.) Will there be General Clean-up VOC Operations?</p> <p><input type="checkbox"/> Yes      <input checked="" type="checkbox"/> No</p> <p><input type="checkbox"/> If YES, complete the GENERAL EMISSIONS UNIT DATA SHEET.</p>
<p>7.) Will there be any other activities that generate fugitive emissions?</p> <p><input type="checkbox"/> Yes      <input checked="" type="checkbox"/> No</p> <p><input type="checkbox"/> If YES, complete the GENERAL EMISSIONS UNIT DATA SHEET or the most appropriate form.</p>
<p>If you answered "NO" to all of the items above, it is not necessary to complete the following table, "Fugitive Emissions Summary."</p>

FUGITIVE EMISSIONS SUMMARY	All Regulated Pollutants - Chemical Name/CAS <sup>1</sup>	Maximum Potential Uncontrolled Emissions <sup>2</sup>		Maximum Potential Controlled Emissions <sup>3</sup>		Est. Method Used <sup>4</sup>
		lb/hr	ton/yr	lb/hr	ton/yr	
Haul Road/Road Dust Emissions Paved Haul Roads						
Unpaved Haul Roads						
Storage Pile Emissions						
Loading/Unloading Operations						
Wastewater Treatment Evaporation & Operations						
Equipment Leaks	CO CO2 CH4 NH3	Does Not Apply	1.47 5.79 0.20 4.73	Does Not Apply	1.47 5.79 0.20 4.73	EE
General Clean-up VOC Emissions						
Other						

<sup>1</sup> List all regulated air pollutants. Speciate VOCs, including all HAPs. Follow chemical name with Chemical Abstracts Service (CAS) number. LIST Acids, CO, CS<sub>2</sub>, VOCs, H<sub>2</sub>S, Inorganics, Lead, Organics, O<sub>3</sub>, NO, NO<sub>2</sub>, SO<sub>2</sub>, SO<sub>3</sub>, etc. DO NOT LIST CO<sub>2</sub>, H<sub>2</sub>, H<sub>2</sub>O, N<sub>2</sub>, O<sub>2</sub>, and Noble Gases.

<sup>2</sup> Give rate with no control equipment operating. If emissions occur for less than 1 hr, then record emissions per batch in minutes (e.g. 5 lb VOC/20 minute batch).

<sup>3</sup> Give rate with proposed control equipment operating. If emissions occur for less than 1 hr, then record emissions per batch in minutes (e.g. 5 lb VOC/20 minute batch).

<sup>4</sup> Indicate method used to determine emission rate as follows: MB = material balance; ST = stack test (give date of test); EE = engineering estimate; O = other (specify).

**ATTACHMENT L**

**EMISSION UNIT DATA SHEET(S)**

## Attachment L EMISSIONS UNIT DATA SHEET GENERAL

To be used for affected sources other than asphalt plants, foundries, incinerators, indirect heat exchangers, and quarries.

Identification Number (as assigned on *Equipment List Form*): 1S

**1. Name or type and model of proposed affected source:**

The Feed Purification Unit includes the following major pieces of equipment:

- K411-Natural Gas Compressor
- R-201-Hydrogenator
- R-202 ½-Sulfur Absorber

**2. On a separate sheet(s), furnish a sketch(es) of this affected source. If a modification is to be made to this source, clearly indicated the change(s). Provide a narrative description of all features of the affected source which may affect the production of air pollutants.**

See *Process Flow Diagram C1 PFD01-Reforming*

The Feed Purification Unit is utilized to purify the inlet Methane Feed Stream. This unit is vented during startups and shutdowns to the Process Gas Vent Flare.

**3. Name(s) and maximum amount of proposed process material(s) charged per hour:**

Stream 2000 PFD01-Reforming	
	Nm <sup>3</sup> /hr
Ar	0
Byproducts	0
C3 to C6	6,816
C7+	120
C2H6	10,526
CH4	181,852
CO	0
CO2	11,504
H2	0
He	46
N2	5,738
H2O	20

**4. Name(s) and maximum amount of proposed material(s) produced per hour:**

Stream 2055 PFD01-Reforming	
	Nm <sup>3</sup> /hr
Ar	2
Byproducts	36
C3 to C6	6,816
C7+	120
C2H6	10,526
CH4	181,850
CO	1,676
CO2	9,854
H2	16,010
He	48
N2	11,642
NH3	18
H2O	170,366

**5. Give chemical reactions, if applicable, that will be involved in the generation of air Pollutants:**

No chemical reaction.

\* The identification number which appears here must correspond to the air pollution control device identification number appearing on the *List Form*.

6. Combustion Data (if applicable):			
(a) Type and amount in appropriate units of fuel(s) to be burned:			
(b) Chemical analysis of proposed fuel(s), excluding coal, including maximum percent sulfur and ash:			
(c) Theoretical combustion air requirement (ACF/unit of fuel):			
@		°F and	psia.
(d) Percent excess air: NA			
(e) Type and BTU/hr of burners and all other firing equipment planned to be used:			
(f) If coal is proposed as a source of fuel, identify supplier and seams and give sizing of the coal as it will be fired:			
(g) Proposed maximum design heat input:		NA	× 10 <sup>6</sup> BTU/hr.
7. Projected operating schedule:			
Hours/Day	24	Days/Week	7
		Weeks/Year	52

8. Projected amount of pollutants that would be emitted from this affected source if no control devices were used:

The Feed Purification Unit vents to the Process Gas Vent Flare during routine Startups/Shutdown. It does not have a steady state vent, safety valve venting to the Process Gas Vent Flare could occur during upset conditions.

Values shown below represent 1 Startup

a.	NO <sub>x</sub>		lb/hr		Ton/yr
b.	SO <sub>2</sub>		lb/hr		Ton/yr
c.	CO		lb/hr		Ton/yr
d.	PM <sub>10</sub>		lb/hr		Ton/yr
e.	Hydrocarbons		lb/hr		Ton/yr
f.	VOCs (Ethane & Methane)	27,973	lb/hr	167.84	Ton/yr
g.	Pb		lb/hr		Ton/yr
h.	Specify other(s)				
	CO <sub>2</sub>	4,474	lb/hr	26.8	Ton/yr
			lb/hr		Ton/yr
			lb/hr		Ton/yr
			lb/hr		Ton/yr

NOTE: (1) An Air Pollution Control Device Sheet must be completed for any air pollution device(s) used to control emissions from this affected source.

(2) Complete the Emission Points Data Sheet.

9. Projected amount of pollutants that would be emitted from this affected source if no control devices were used:

The Feed Purification Unit vents to the Process Gas Vent Flare during routine Startups/Shutdown. It does not have a steady state vent, safety valve venting to the Process Gas Vent Flare could occur during upset conditions.

Values shown below represent 1 Shutdown

a.	NO <sub>x</sub>		lb/hr		Ton/yr
b.	SO <sub>2</sub>		lb/hr		Ton/yr
c.	CO		lb/hr		Ton/yr
d.	PM <sub>10</sub>		lb/hr		Ton/yr
e.	Hydrocarbons		lb/hr		Ton/yr
f.	VOCs (Ethane & Methane)	27,973	lb/hr	28.5	Ton/yr
g.	Pb		lb/hr		Ton/yr
h.	Specify other(s)				
	CO <sub>2</sub>	4,474	lb/hr	4.6	Ton/yr
	NH <sub>3</sub>	29	lb/hr	.02	Ton/yr
			lb/hr		Ton/yr
			lb/hr		Ton/yr



10. Proposed Monitoring, Recordkeeping, Reporting, and Testing  
 Please propose monitoring, recordkeeping, and reporting in order to demonstrate compliance with the proposed operating parameters. Please propose testing in order to demonstrate compliance with the proposed emissions limits.

**MONITORING**

None Proposed

**RECORDKEEPING**

Track the amount of sulfur produced.

**REPORTING**

None Proposed

**TESTING**

None Proposed

**MONITORING.** PLEASE LIST AND DESCRIBE THE PROCESS PARAMETERS AND RANGES THAT ARE PROPOSED TO BE MONITORED IN ORDER TO DEMONSTRATE COMPLIANCE WITH THE OPERATION OF THIS PROCESS EQUIPMENT OPERATION/AIR POLLUTION CONTROL DEVICE.

**RECORDKEEPING.** PLEASE DESCRIBE THE PROPOSED RECORDKEEPING THAT WILL ACCOMPANY THE MONITORING.

**REPORTING.** PLEASE DESCRIBE THE PROPOSED FREQUENCY OF REPORTING OF THE RECORDKEEPING.

**TESTING.** PLEASE DESCRIBE ANY PROPOSED EMISSIONS TESTING FOR THIS PROCESS EQUIPMENT/AIR POLLUTION CONTROL DEVICE.

10. Describe all operating ranges and maintenance procedures required by Manufacturer to maintain warranty

This unit is specifically designed for each process and the final design has not been completed. Operating ranges and maintenance procedures will be identified during final design of each unit within the system. The procedures as identified will be followed.

**Attachment L**  
**EMISSIONS UNIT DATA SHEET**  
**GENERAL**

To be used for affected sources other than asphalt plants, foundries, incinerators, indirect heat exchangers, and quarries.

Identification Number (as assigned on *Equipment List Form*): 2S

1. Name or type and model of proposed affected source:

The Reformer Section includes the following major pieces of equipment:

- R-203 PreReformer

2. On a separate sheet(s), furnish a sketch(es) of this affected source. If a modification is to be made to this source, clearly indicated the change(s). Provide a narrative description of all features of the affected source which may affect the production of air pollutants.

See *Process Flow Diagram C1 PFD01-Reforming*

The Reformer Section is to condition Methane Gas feed stream for downstream reforming. This unit is vented during startups and shutdowns to the Process Gas Vent Flare.

3. Name(s) and maximum amount of proposed process material(s) charged per hour:

Stream 2055 PFD01-Reforming

	Nm <sup>3</sup> /hr
Ar	2
Byproducts	36
C3 to C6	6,816
C7+	120
C2H6	10,526
CH4	181,850
CO	1,676
CO2	9,854
H2	16,010
He	48
N2	11,642
NH3	18
H2O	170,366

4. Name(s) and maximum amount of proposed material(s) produced per hour:

Stream 2060 PFD01-Reforming

	Nm <sup>3</sup> /hr
Ar	2
Byproducts	0
CH4	218,752
CO	436
CO2	19,534
H2	23,018
He	48
N2	11,650
H2O	152,286

5. Give chemical reactions, if applicable, that will be involved in the generation of air pollutants:

No chemical reaction.

\* The identification number which appears here must correspond to the air pollution control device identification number appearing on the *List Form*.

6. Combustion Data (if applicable):			
(a) Type and amount in appropriate units of fuel(s) to be burned:			
(b) Chemical analysis of proposed fuel(s), excluding coal, including maximum percent sulfur and ash:			
(c) Theoretical combustion air requirement (ACF/unit of fuel):			
@		°F and	psia.
(d) Percent excess air: NA			
(e) Type and BTU/hr of burners and all other firing equipment planned to be used:			
(f) If coal is proposed as a source of fuel, identify supplier and seams and give sizing of the coal as it will be fired:			
(g) Proposed maximum design heat input:		NA	× 10 <sup>6</sup> BTU/hr.
7. Projected operating schedule:			
Hours/Day	24	Days/Week	7
		Weeks/Year	52

8. Projected amount of pollutants that would be emitted from this affected source if no control devices were used:

The Reformer Section vents to the Process Gas Vent Flare during routine Startups/Shutdown. It does not have a steady state vent, safety valve venting to the Process Gas Vent Flare could occur during upset conditions.

Values shown are for 1 Startup

a.	NO <sub>x</sub>		lb/hr		Ton/yr
b.	SO <sub>2</sub>		lb/hr		Ton/yr
c.	CO		lb/hr		Ton/yr
d.	PM <sub>10</sub>		lb/hr		Ton/yr
e.	Hydrocarbons		lb/hr		Ton/yr
f.	VOCs (Ethane & Methane)	46,717	lb/hr	467.2	Ton/yr
g.	Pb		lb/hr		Ton/yr
h.	Specify other(s)				
	CO <sub>2</sub>	16,351	lb/hr	163.5	Ton/yr
			lb/hr		Ton/yr
			lb/hr		Ton/yr
			lb/hr		Ton/yr

NOTE: (1) An Air Pollution Control Device Sheet must be completed for any air pollution device(s) used to control emissions from this affected source.

(2) Complete the Emission Points Data Sheet.

9. Projected amount of pollutants that would be emitted from this affected source if no control devices were used:

The Reformer Section vents to the Process Gas Vent Flare during routine Startups/Shutdown. It does not have a steady state vent, safety valve venting to the Process Gas Vent Flare could occur during upset conditions.

Values shown are for 1 Shutdown

a.	NO <sub>x</sub>		lb/hr		Ton/yr
b.	SO <sub>2</sub>		lb/hr		Ton/yr
c.	CO		lb/hr		Ton/yr
d.	PM <sub>10</sub>		lb/hr		Ton/yr
e.	Hydrocarbons		lb/hr		Ton/yr
f.	VOCs (Ethane & Methane)	46,717	lb/hr	79.4	Ton/yr
g.	Pb		lb/hr		Ton/yr
h.	Specify other(s)				
	CO <sub>2</sub>	16,351	lb/hr	27.8	Ton/yr
			lb/hr		Ton/yr
			lb/hr		Ton/yr
			lb/hr		Ton/yr

10. Proposed Monitoring, Recordkeeping, Reporting, and Testing  
 Please propose monitoring, recordkeeping, and reporting in order to demonstrate compliance with the proposed operating parameters. Please propose testing in order to demonstrate compliance with the proposed emissions limits.

**MONITORING**

None Proposed

**RECORDKEEPING**

Track the amount of sulfur produced.

**REPORTING**

None Proposed

**TESTING**

None Proposed

**MONITORING.** PLEASE LIST AND DESCRIBE THE PROCESS PARAMETERS AND RANGES THAT ARE PROPOSED TO BE MONITORED IN ORDER TO DEMONSTRATE COMPLIANCE WITH THE OPERATION OF THIS PROCESS EQUIPMENT OPERATION/AIR POLLUTION CONTROL DEVICE.

**RECORDKEEPING.** PLEASE DESCRIBE THE PROPOSED RECORDKEEPING THAT WILL ACCOMPANY THE MONITORING.

**REPORTING.** PLEASE DESCRIBE THE PROPOSED FREQUENCY OF REPORTING OF THE RECORDKEEPING.

**TESTING.** PLEASE DESCRIBE ANY PROPOSED EMISSIONS TESTING FOR THIS PROCESS EQUIPMENT/AIR POLLUTION CONTROL DEVICE.

10. Describe all operating ranges and maintenance procedures required by Manufacturer to maintain warranty

This unit is specifically designed for each process and the final design has not been completed. Operating ranges and maintenance procedures will be identified during final design of each unit within the system. The procedures as identified will be followed.

## Attachment L EMISSIONS UNIT DATA SHEET GENERAL

To be used for affected sources other than asphalt plants, foundries, incinerators, indirect heat exchangers, and quarries.

Identification Number (as assigned on *Equipment List Form*): 3S

1. Name or type and model of proposed affected source:

The ATR Section includes the following major pieces of equipment:

- R-204 AutoThermal Reformer (ATR)
- E-208 Waste Heat Boiler

2. On a separate sheet(s), furnish a sketch(es) of this affected source. If a modification is to be made to this source, clearly indicated the change(s). Provide a narrative description of all features of the affected source which may affect the production of air pollutants.

See *Process Flow Diagram C1 PFD01-Reforming*

The ATR Section is utilized to reform the Methane gas feed stream into Carbon Dioxide. This unit is vented during startups and shutdowns to the Process Gas Vent Flare.

3. Name(s) and maximum amount of proposed process material(s) charged per hour:

Stream 2060 PFD01-Reforming	
	Nm <sup>3</sup> /hr
Ar	2
Byproducts	0
CH <sub>4</sub>	218,752
CO	436
CO <sub>2</sub>	19,534
H <sub>2</sub>	23,018
He	48
N <sub>2</sub>	11,650
H <sub>2</sub> O	152,286

4. Name(s) and maximum amount of proposed material(s) produced per hour:

Stream 2105 PFD02-Shift	
	Nm <sup>3</sup> /hr
Ar	29,882
Byproducts	6
CH <sub>4</sub>	7,998
CO	214,386
CO <sub>2</sub>	50,524
H <sub>2</sub>	450,754
He	48
N <sub>2</sub>	36,476
H <sub>2</sub> O	200,874

5. Give chemical reactions, if applicable, that will be involved in the generation of air pollutants:

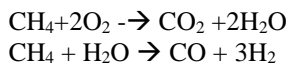

\* The identification number which appears here must correspond to the air pollution control device identification number appearing on the *List Form*.

6. Combustion Data (if applicable):			
(a) Type and amount in appropriate units of fuel(s) to be burned:			
(b) Chemical analysis of proposed fuel(s), excluding coal, including maximum percent sulfur and ash:			
(c) Theoretical combustion air requirement (ACF/unit of fuel):			
@		°F and	psia.
(d) Percent excess air: NA			
(e) Type and BTU/hr of burners and all other firing equipment planned to be used:			
(f) If coal is proposed as a source of fuel, identify supplier and seams and give sizing of the coal as it will be fired:			
(g) Proposed maximum design heat input:		NA	× 10 <sup>6</sup> BTU/hr.
7. Projected operating schedule:			
Hours/Day	24	Days/Week	7
		Weeks/Year	52



8. Projected amount of pollutants that would be emitted from this affected source if no control devices were used:

The ATR Section vents to the Process Gas Vent Flare during routine Startups/Shutdown. It does not have a steady state vent, safety valve venting to the Process Gas Vent Flare could occur during upset conditions.

Values shown are for 1 Startup

a.	NO <sub>x</sub>		lb/hr		Ton/yr
b.	SO <sub>2</sub>		lb/hr		Ton/yr
c.	CO	14,691	lb/hr	110.2	Ton/yr
d.	PM <sub>10</sub>		lb/hr		Ton/yr
e.	Hydrocarbons		lb/hr		Ton/yr
f.	VOCs (Ethane & Methane)	42,848	lb/hr	321.4	Ton/yr
g.	Pb		lb/hr		Ton/yr
h.	Specify other(s)				
	CO <sub>2</sub>	132,604	lb/hr	994.5	Ton/yr
			lb/hr		Ton/yr
			lb/hr		Ton/yr
			lb/hr		Ton/yr

NOTE: (1) An Air Pollution Control Device Sheet must be completed for any air pollution device(s) used to control emissions from this affected source.

(2) Complete the Emission Points Data Sheet.

9. Projected amount of pollutants that would be emitted from this affected source if no control devices were used:

The ATR Section vents to the Process Gas Vent Flare during routine Startups/Shutdown. It does not have a steady state vent, safety valve venting to the Process Gas Vent Flare could occur during upset conditions.

Values shown are for 1 Shutdown

a.	NO <sub>x</sub>		lb/hr		Ton/yr
b.	SO <sub>2</sub>		lb/hr		Ton/yr
c.	CO		lb/hr		Ton/yr
d.	PM <sub>10</sub>		lb/hr		Ton/yr
e.	Hydrocarbons		lb/hr		Ton/yr
f.	VOCs (Ethane & Methane)	42,848	lb/hr	54.6	Ton/yr
g.	Pb		lb/hr		Ton/yr
h.	Specify other(s)				
	CO <sub>2</sub>	132,604	lb/hr	169.1	Ton/yr
			lb/hr		Ton/yr
			lb/hr		Ton/yr
			lb/hr		Ton/yr

10. Proposed Monitoring, Recordkeeping, Reporting, and Testing  
 Please propose monitoring, recordkeeping, and reporting in order to demonstrate compliance with the proposed operating parameters. Please propose testing in order to demonstrate compliance with the proposed emissions limits.

**MONITORING**

None Proposed

**RECORDKEEPING**

Track the amount of sulfur produced.

**REPORTING**

None Proposed

**TESTING**

None Proposed

**MONITORING.** PLEASE LIST AND DESCRIBE THE PROCESS PARAMETERS AND RANGES THAT ARE PROPOSED TO BE MONITORED IN ORDER TO DEMONSTRATE COMPLIANCE WITH THE OPERATION OF THIS PROCESS EQUIPMENT OPERATION/AIR POLLUTION CONTROL DEVICE.

**RECORDKEEPING.** PLEASE DESCRIBE THE PROPOSED RECORDKEEPING THAT WILL ACCOMPANY THE MONITORING.

**REPORTING.** PLEASE DESCRIBE THE PROPOSED FREQUENCY OF REPORTING OF THE RECORDKEEPING.

**TESTING.** PLEASE DESCRIBE ANY PROPOSED EMISSIONS TESTING FOR THIS PROCESS EQUIPMENT/AIR POLLUTION CONTROL DEVICE.

10. Describe all operating ranges and maintenance procedures required by Manufacturer to maintain warranty

This unit is specifically designed for each process and the final design has not been completed. Operating ranges and maintenance procedures will be identified during final design of each unit within the system. The procedures as identified will be followed.

**Attachment L**  
**EMISSIONS UNIT DATA SHEET**  
**GENERAL**

To be used for affected sources other than asphalt plants, foundries, incinerators, indirect heat exchangers, and quarries.

Identification Number (as assigned on *Equipment List Form*): 4S

1. Name or type and model of proposed affected source:

The CO Conversion Section includes the following major pieces of equipment:

- R-205 High Temperature Shift Converter
- R-206 Medium Temperature Shift Converter
- E-213 BFW PreHeater
- C-301 HP Regenerator
- C-303 LP Regenerator

2. On a separate sheet(s), furnish a sketch(es) of this affected source. If a modification is to be made to this source, clearly indicated the change(s). Provide a narrative description of all features of the affected source which may affect the production of air pollutants.

See *Process Flow Diagram C1 PFD02-Shift*

The CO Conversion Section is utilized to continue converting Methane feed into Carbon Dioxide, CO<sub>2</sub>, Hydrogen and Water. This unit is vented during startups and shutdowns to the Process Gas Vent Flare.

3. Name(s) and maximum amount of proposed process material(s) charged per hour:

Stream 2105 PFD02-Shift	
	Nm <sup>3</sup> /hr
Ar	29,882
Byproducts	6
CH <sub>4</sub>	7,998
CO	214,386
CO <sub>2</sub>	50,524
H <sub>2</sub>	450,754
He	48
N <sub>2</sub>	36,476
H <sub>2</sub> O	200,874

4. Name(s) and maximum amount of proposed material(s) produced per hour:

Stream 2160 PFD02-Shift	
	Nm <sup>3</sup> /hr
Ar	29,888
Byproducts	1,014
CH <sub>4</sub>	8,000
CO	26,924
CO <sub>2</sub>	238,550
H <sub>2</sub>	637,990
He	48
N <sub>2</sub>	36,478
H <sub>2</sub> O	208,566

5. Give chemical reactions, if applicable, that will be involved in the generation of air pollutants:

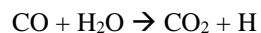
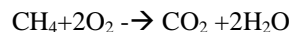

\* The identification number which appears here must correspond to the air pollution control device identification number appearing on the *List Form*.

6. Combustion Data (if applicable):			
(a) Type and amount in appropriate units of fuel(s) to be burned:			
(b) Chemical analysis of proposed fuel(s), excluding coal, including maximum percent sulfur and ash:			
(c) Theoretical combustion air requirement (ACF/unit of fuel):			
@		°F and	psia.
(d) Percent excess air: NA			
(e) Type and BTU/hr of burners and all other firing equipment planned to be used:			
(f) If coal is proposed as a source of fuel, identify supplier and seams and give sizing of the coal as it will be fired:			
(g) Proposed maximum design heat input:		NA	× 10 <sup>6</sup> BTU/hr.
7. Projected operating schedule:			
Hours/Day	24	Days/Week	7
		Weeks/Year	52

8. Projected amount of pollutants that would be emitted from this affected source if no control devices were used:

The CO Conversion Section vents to the Process Gas Vent Flare during routine Startups/Shutdown. It does not have a steady state vent, safety valve venting to the Process Gas Vent Flare could occur during upset conditions.

Values shown are for 1 Startup

a.	NO <sub>x</sub>		lb/hr		Ton/yr
b.	SO <sub>2</sub>		lb/hr		Ton/yr
c.	CO	85,554	lb/hr	171.1	Ton/yr
d.	PM <sub>10</sub>		lb/hr		Ton/yr
e.	Hydrocarbons		lb/hr		Ton/yr
f.	VOCs (Ethane & Methane)	6,173	lb/hr	12.3	Ton/yr
g.	Pb		lb/hr		Ton/yr
h.	Specify other(s)				
	CO <sub>2</sub>	428,480	lb/hr	857.0	Ton/yr
			lb/hr		Ton/yr
			lb/hr		Ton/yr
			lb/hr		Ton/yr

NOTE: (1) An Air Pollution Control Device Sheet must be completed for any air pollution device(s) used to control emissions from this affected source.

(2) Complete the Emission Points Data Sheet.

9. Projected amount of pollutants that would be emitted from this affected source if no control devices were used:

The CO Conversion Section vents to the Process Gas Vent Flare during routine Startups/Shutdown. It does not have a steady state vent, safety valve venting to the Process Gas Vent Flare could occur during upset conditions.

Values shown are for 1 Shutdown

a.	NO <sub>x</sub>		lb/hr		Ton/yr
b.	SO <sub>2</sub>		lb/hr		Ton/yr
c.	CO	85,554	lb/hr	29.1	Ton/yr
d.	PM <sub>10</sub>		lb/hr		Ton/yr
e.	Hydrocarbons		lb/hr		Ton/yr
f.	VOCs (Ethane & Methane)	6,173	lb/hr	2.1	Ton/yr
g.	Pb		lb/hr		Ton/yr
h.	Specify other(s)				
	CO <sub>2</sub>	428,480	lb/hr	145.7	Ton/yr
			lb/hr		Ton/yr
			lb/hr		Ton/yr
			lb/hr		Ton/yr

10. Proposed Monitoring, Recordkeeping, Reporting, and Testing  
 Please propose monitoring, recordkeeping, and reporting in order to demonstrate compliance with the proposed operating parameters. Please propose testing in order to demonstrate compliance with the proposed emissions limits.

**MONITORING**

None Proposed

**RECORDKEEPING**

Track the amount of sulfur produced.

**REPORTING**

None Proposed

**TESTING**

None Proposed

**MONITORING.** PLEASE LIST AND DESCRIBE THE PROCESS PARAMETERS AND RANGES THAT ARE PROPOSED TO BE MONITORED IN ORDER TO DEMONSTRATE COMPLIANCE WITH THE OPERATION OF THIS PROCESS EQUIPMENT OPERATION/AIR POLLUTION CONTROL DEVICE.

**RECORDKEEPING.** PLEASE DESCRIBE THE PROPOSED RECORDKEEPING THAT WILL ACCOMPANY THE MONITORING.

**REPORTING.** PLEASE DESCRIBE THE PROPOSED FREQUENCY OF REPORTING OF THE RECORDKEEPING.

**TESTING.** PLEASE DESCRIBE ANY PROPOSED EMISSIONS TESTING FOR THIS PROCESS EQUIPMENT/AIR POLLUTION CONTROL DEVICE.

10. Describe all operating ranges and maintenance procedures required by Manufacturer to maintain warranty

This unit is specifically designed for each process and the final design has not been completed. Operating ranges and maintenance procedures will be identified during final design of each unit within the system. The procedures as identified will be followed.



## Attachment L EMISSIONS UNIT DATA SHEET GENERAL

To be used for affected sources other than asphalt plants, foundries, incinerators, indirect heat exchangers, and quarries.

Identification Number (as assigned on *Equipment List Form*): 5S

1. Name or type and model of proposed affected source:

The Nitrogen Wash Unit includes the following major pieces of equipment:

- V-311 Final Separator
- X-302 Nitrogen Wash Unit
- K-401 Recycle Off-Gas Compressor

2. On a separate sheet(s), furnish a sketch(es) of this affected source. If a modification is to be made to this source, clearly indicated the change(s). Provide a narrative description of all features of the affected source which may affect the production of air pollutants.

See *Process Flow Diagram C1 PFD04-NWU*

The Nitrogen Wash Unit is utilized to purify the feed stream of Hydrogen going downstream to the Ammonia Loop Section. This unit is vented during startups and shutdowns to the Process Gas Vent Flare.

3. Name(s) and maximum amount of proposed process material(s) charged per hour:

Stream 2300 PFD03-GV

	Nm <sup>3</sup> /hr
Ar	29,882
Byproducts	48
CH <sub>4</sub>	7,998
CO	26,898
CO <sub>2</sub>	110
H <sub>2</sub>	636,196
He	48
N <sub>2</sub>	36,452
NH <sub>3</sub>	240
H <sub>2</sub> O	5,502

4. Name(s) and maximum amount of proposed material(s) produced per hour:

Stream 2330 PFD03-GV

	Nm <sup>3</sup> /hr
Ar	12
Byproducts	0
CH <sub>4</sub>	0
CO	0
CO <sub>2</sub>	0
H <sub>2</sub>	513,016
He	38
N <sub>2</sub>	171,106
NH <sub>3</sub>	74
H <sub>2</sub> O	0

5. Give chemical reactions, if applicable, that will be involved in the generation of air pollutants:

No chemical reaction.

\* The identification number which appears here must correspond to the air pollution control device identification number appearing on the *List Form*.

6. Combustion Data (if applicable):			
(a) Type and amount in appropriate units of fuel(s) to be burned:			
(b) Chemical analysis of proposed fuel(s), excluding coal, including maximum percent sulfur and ash:			
(c) Theoretical combustion air requirement (ACF/unit of fuel):			
@		°F and	psia.
(d) Percent excess air: NA			
(e) Type and BTU/hr of burners and all other firing equipment planned to be used:			
(f) If coal is proposed as a source of fuel, identify supplier and seams and give sizing of the coal as it will be fired:			
(g) Proposed maximum design heat input:		NA	× 10 <sup>6</sup> BTU/hr.
7. Projected operating schedule:			
Hours/Day	24	Days/Week	7
		Weeks/Year	52

8. Projected amount of pollutants that would be emitted from this affected source if no control devices were used:

The Nitrogen Wash Unit vents to the Process Gas Vent Flare during routine Startups/Shutdown. It does not have a steady state vent, safety valve venting to the Process Gas Vent Flare could occur during upset conditions.

Values shown are a for 1 Startup

a.	NO <sub>x</sub>		lb/hr		Ton/yr
b.	SO <sub>2</sub>		lb/hr		Ton/yr
c.	CO	20,281	lb/hr	20.28	Ton/yr
d.	PM <sub>10</sub>		lb/hr		Ton/yr
e.	Hydrocarbons		lb/hr		Ton/yr
f.	VOCs (Ethane & Methane)	3,703	lb/hr	3.7	Ton/yr
g.	Pb		lb/hr		Ton/yr
h.	Specify other(s)				
	CO <sub>2</sub>	64.8	lb/hr	0.06	Ton/yr
			lb/hr		Ton/yr
			lb/hr		Ton/yr
			lb/hr		Ton/yr

NOTE: (1) An Air Pollution Control Device Sheet must be completed for any air pollution device(s) used to control emissions from this affected source.

(2) Complete the Emission Points Data Sheet.

9. Projected amount of pollutants that would be emitted from this affected source if no control devices were used:

The Nitrogen Wash Unit vents to the Process Gas Vent Flare during routine Startups/Shutdown. It does not have a steady state vent, safety valve venting to the Process Gas Vent Flare could occur during upset conditions.

Values shown are for 1 Shutdown

a.	NO <sub>x</sub>		lb/hr		Ton/yr
b.	SO <sub>2</sub>		lb/hr		Ton/yr
c.	CO	20,281	lb/hr	3.45	Ton/yr
d.	PM <sub>10</sub>		lb/hr		Ton/yr
e.	Hydrocarbons		lb/hr		Ton/yr
f.	VOCs (Ethane & Methane)	3,703	lb/hr	0.63	Ton/yr
g.	Pb		lb/hr		Ton/yr
h.	Specify other(s)				
	CO <sub>2</sub>	64.8	lb/hr	0.01	Ton/yr
	NH <sub>3</sub>	118.8	lb/hr	0.12	Ton/yr
			lb/hr		Ton/yr
			lb/hr		Ton/yr

10. Proposed Monitoring, Recordkeeping, Reporting, and Testing  
 Please propose monitoring, recordkeeping, and reporting in order to demonstrate compliance with the proposed operating parameters. Please propose testing in order to demonstrate compliance with the proposed emissions limits.

**MONITORING**  
 None Proposed

**RECORDKEEPING**  
 Track the amount of sulfur produced.

**REPORTING**  
 None Proposed

**TESTING**  
 None Proposed

**MONITORING.** PLEASE LIST AND DESCRIBE THE PROCESS PARAMETERS AND RANGES THAT ARE PROPOSED TO BE MONITORED IN ORDER TO DEMONSTRATE COMPLIANCE WITH THE OPERATION OF THIS PROCESS EQUIPMENT OPERATION/AIR POLLUTION CONTROL DEVICE.

**RECORDKEEPING.** PLEASE DESCRIBE THE PROPOSED RECORDKEEPING THAT WILL ACCOMPANY THE MONITORING.

**REPORTING.** PLEASE DESCRIBE THE PROPOSED FREQUENCY OF REPORTING OF THE RECORDKEEPING.

**TESTING.** PLEASE DESCRIBE ANY PROPOSED EMISSIONS TESTING FOR THIS PROCESS EQUIPMENT/AIR POLLUTION CONTROL DEVICE.

10. Describe all operating ranges and maintenance procedures required by Manufacturer to maintain warranty  
 This unit is specifically designed for each process and the final design has not been completed. Operating ranges and maintenance procedures will be identified during final design of each unit within the system. The procedures as identified will be followed.

**Attachment L**  
**EMISSIONS UNIT DATA SHEET**  
**GENERAL**

To be used for affected sources other than asphalt plants, foundries, incinerators, indirect heat exchangers, and quarries.

Identification Number (as assigned on *Equipment List Form*): 6S

**1. Name or type and model of proposed affected source:**

The Ammonia Loop Unit includes the following major pieces of equipment:

- K-431 Synthesis Gas Compressor
- R-501 Ammonia Converter
- V-501 Ammonia Separator
- V-503 Flash Vessel
- C-501 Off Gas Absorber

**2. On a separate sheet(s), furnish a sketch(es) of this affected source. If a modification is to be made to this source, clearly indicated the change(s). Provide a narrative description of all features of the affected source which may affect the production of air pollutants.**

See *Process Flow Diagram C1 PFD06-Refrig*

The Ammonia Loop Unit is utilized to convert Hydrogen gas feed into the final Ammonia product. This unit is vented during startups and shutdowns to the Process Gas Vent Flare.

**3. Name(s) and maximum amount of proposed process material(s) charged per hour:**

Stream 2330 PFD03-GV

	Nm <sup>3</sup> /hr
Ar	12
Byproducts	0
CH4	0
CO	0
CO2	0
H2	513,016
He	38
N2	171,106
NH3	74
H2O	0

**4. Name(s) and maximum amount of proposed material(s) produced per hour:**

Stream 7845 PFD06-Refrig

	Nm <sup>3</sup> /hr
Ar	12
Byproducts	0
CH4	0
CO	0
CO2	0
H2	1,246
He	36
N2	506
NH3	0
H2O	14

**5. Give chemical reactions, if applicable, that will be involved in the generation of air pollutants:**

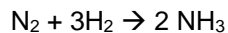

\* The identification number which appears here must correspond to the air pollution control device identification number appearing on the *List Form*.

6. Combustion Data (if applicable):			
(a) Type and amount in appropriate units of fuel(s) to be burned:			
(b) Chemical analysis of proposed fuel(s), excluding coal, including maximum percent sulfur and ash:			
(c) Theoretical combustion air requirement (ACF/unit of fuel):			
@		°F and	psia.
(d) Percent excess air: NA			
(e) Type and BTU/hr of burners and all other firing equipment planned to be used:			
(f) If coal is proposed as a source of fuel, identify supplier and seams and give sizing of the coal as it will be fired:			
(g) Proposed maximum design heat input:		NA	× 10 <sup>6</sup> BTU/hr.
7. Projected operating schedule:			
Hours/Day	24	Days/Week	7
		Weeks/Year	52

8. Projected amount of pollutants that would be emitted from this affected source if no control devices were used:

The Ammonia Loop Unit vents to the Ammonia Gas Vent Flare during routine Startups/Shutdown. It does not have a steady state vent, safety valve venting to the Ammonia Gas Vent Flare could occur during upset conditions.

Values shown are for 1 Startup

a.	NO <sub>x</sub>		lb/hr		Ton/yr
b.	SO <sub>2</sub>		lb/hr		Ton/yr
c.	CO		lb/hr		Ton/yr
d.	PM <sub>10</sub>		lb/hr		Ton/yr
e.	Hydrocarbons		lb/hr		Ton/yr
f.	VOCs		lb/hr		Ton/yr
g.	Pb		lb/hr		Ton/yr
h.	Specify other(s)				
	NH <sub>3</sub>	87.6	lb/hr	0.26	Ton/yr
			lb/hr		Ton/yr
			lb/hr		Ton/yr
			lb/hr		Ton/yr

NOTE: (1) An Air Pollution Control Device Sheet must be completed for any air pollution device(s) used to control emissions from this affected source.

(2) Complete the Emission Points Data Sheet.



9. Projected amount of pollutants that would be emitted from this affected source if no control devices were used:

The Ammonia Loop Unit vents to the Ammonia Gas Vent Flare during routine Startups/Shutdown. It does not have a steady state vent, safety valve venting to the Ammonia Gas Vent Flare could occur during upset conditions.

Values shown are for 1 Shutdown

a.	NO <sub>x</sub>		lb/hr		Ton/yr
b.	SO <sub>2</sub>		lb/hr		Ton/yr
c.	CO		lb/hr		Ton/yr
d.	PM <sub>10</sub>		lb/hr		Ton/yr
e.	Hydrocarbons		lb/hr		Ton/yr
f.	VOCs		lb/hr		Ton/yr
g.	Pb		lb/hr		Ton/yr
h.	Specify other(s)				
	NH <sub>3</sub>	87.6	lb/hr	0.04	Ton/yr
			lb/hr		Ton/yr
			lb/hr		Ton/yr
			lb/hr		Ton/yr

10. Proposed Monitoring, Recordkeeping, Reporting, and Testing  
 Please propose monitoring, recordkeeping, and reporting in order to demonstrate compliance with the proposed operating parameters. Please propose testing in order to demonstrate compliance with the proposed emissions limits.

**MONITORING**  
 None Proposed

**RECORDKEEPING**  
 Track the amount of sulfur produced.

**REPORTING**  
 None Proposed

**TESTING**  
 None Proposed

**MONITORING.** PLEASE LIST AND DESCRIBE THE PROCESS PARAMETERS AND RANGES THAT ARE PROPOSED TO BE MONITORED IN ORDER TO DEMONSTRATE COMPLIANCE WITH THE OPERATION OF THIS PROCESS EQUIPMENT OPERATION/AIR POLLUTION CONTROL DEVICE.

**RECORDKEEPING.** PLEASE DESCRIBE THE PROPOSED RECORDKEEPING THAT WILL ACCOMPANY THE MONITORING.

**REPORTING.** PLEASE DESCRIBE THE PROPOSED FREQUENCY OF REPORTING OF THE RECORDKEEPING.

**TESTING.** PLEASE DESCRIBE ANY PROPOSED EMISSIONS TESTING FOR THIS PROCESS EQUIPMENT/AIR POLLUTION CONTROL DEVICE.

10. Describe all operating ranges and maintenance procedures required by Manufacturer to maintain warranty  
 This unit is specifically designed for each process and the final design has not been completed. Operating ranges and maintenance procedures will be identified during final design of each unit within the system. The procedures as identified will be followed.

## Attachment L EMISSIONS UNIT DATA SHEET GENERAL

To be used for affected sources other than asphalt plants, foundries, incinerators, indirect heat exchangers, and quarries.

Identification Number (as assigned on *Equipment List Form*): CO2 Removal Section

1. Name or type and model of proposed affected source:

The CO2 Removal Section includes the following major pieces of equipment:

- C-301 HP Regenerator
- C-303 LP Regenerator
- C-302 CO2 Absorber

2. On a separate sheet(s), furnish a sketch(es) of this affected source. If a modification is to be made to this source, clearly indicated the change(s). Provide a narrative description of all features of the affected source which may affect the production of air pollutants.

See *Process Flow Diagram C1 PFD03-GV*

The CO2 Removal Section is utilized to remove and sequester CO2 from the process stream. This unit is vented during startups and shutdowns to the Process Gas Vent Flare.

3. Name(s) and maximum amount of proposed process material(s) charged per hour:

Stream 2160 PFD02-Shift	
	Nm <sup>3</sup> /hr
Ar	29,888
Byproducts	1,014
CH4	8,000
CO	26,924
CO2	238,550
H2	637,990
He	48
N2	36,478
H2O	208,566

4. Name(s) and maximum amount of proposed material(s) produced per hour:

Stream 2300 PFD03-GV	
	Nm <sup>3</sup> /hr
Ar	29,882
Byproducts	48
CH4	7,998
CO	26,898
CO2	110
H2	636,196
He	48
N2	36,452
NH3	240
H2O	5,502

5. Give chemical reactions, if applicable, that will be involved in the generation of air pollutants:

No chemical reaction.

\* The identification number which appears here must correspond to the air pollution control device identification number appearing on the *List Form*.

6. Combustion Data (if applicable):			
(a) Type and amount in appropriate units of fuel(s) to be burned:			
(b) Chemical analysis of proposed fuel(s), excluding coal, including maximum percent sulfur and ash:			
(c) Theoretical combustion air requirement (ACF/unit of fuel):			
@		°F and	psia.
(d) Percent excess air: NA			
(e) Type and BTU/hr of burners and all other firing equipment planned to be used:			
(f) If coal is proposed as a source of fuel, identify supplier and seams and give sizing of the coal as it will be fired:			
(g) Proposed maximum design heat input:		NA	× 10 <sup>6</sup> BTU/hr.
7. Projected operating schedule:			
Hours/Day	24	Days/Week	7
		Weeks/Year	52

8. Projected amount of pollutants that would be emitted from this affected source if no control devices were used:

The CO2 Removal Section vents to the Process Gas Vent Flare during routine Startups/Shutdown. It does not have a steady state vent, safety valve venting to the Process Gas Vent Flare could occur during upset conditions.

Values shown are for 1 Annual Startup

a.	NO <sub>x</sub>		lb/hr		Ton/yr
b.	SO <sub>2</sub>		lb/hr		Ton/yr
c.	CO	33,801	lb/hr	16.90	Ton/yr
d.	PM <sub>10</sub>		lb/hr		Ton/yr
e.	Hydrocarbons		lb/hr		Ton/yr
f.	VOCs (Ethane & Methane)	6,172	lb/hr	3.08	Ton/yr
g.	Pb		lb/hr		Ton/yr
h.	Specify other(s)				
	CO <sub>2</sub>	238	lb/hr	0.12	Ton/yr
			lb/hr		Ton/yr
			lb/hr		Ton/yr
			lb/hr		Ton/yr

NOTE: (1) An Air Pollution Control Device Sheet must be completed for any air pollution device(s) used to control emissions from this affected source.

(2) Complete the Emission Points Data Sheet.

9. Projected amount of pollutants that would be emitted from this affected source if no control devices were used:

The CO2 Removal Section vents to the Process Gas Vent Flare during routine Startups/Shutdown. It does not have a steady state vent, safety valve venting to the Process Gas Vent Flare could occur during upset conditions.

Values shown are a combined number for 1 Annual Shutdown

a.	NO <sub>x</sub>		lb/hr		Ton/yr
b.	SO <sub>2</sub>		lb/hr		Ton/yr
c.	CO	33,801	lb/hr	2.87	Ton/yr
d.	PM <sub>10</sub>		lb/hr		Ton/yr
e.	Hydrocarbons		lb/hr		Ton/yr
f.	VOCs (Ethane & Methane)	6,172	lb/hr	0.52	Ton/yr
g.	Pb		lb/hr		Ton/yr
h.	Specify other(s)				
	CO <sub>2</sub>	238	lb/hr	0.02	Ton/yr
	NH <sub>3</sub>	385	lb/hr	0.4	Ton/yr
			lb/hr		Ton/yr
			lb/hr		Ton/yr

10. Proposed Monitoring, Recordkeeping, Reporting, and Testing  
 Please propose monitoring, recordkeeping, and reporting in order to demonstrate compliance with the proposed operating parameters. Please propose testing in order to demonstrate compliance with the proposed emissions limits.

**MONITORING**  
 None Proposed

**RECORDKEEPING**  
 Track the amount of sulfur produced.

**REPORTING**  
 None Proposed

**TESTING**  
 None Proposed

**MONITORING.** PLEASE LIST AND DESCRIBE THE PROCESS PARAMETERS AND RANGES THAT ARE PROPOSED TO BE MONITORED IN ORDER TO DEMONSTRATE COMPLIANCE WITH THE OPERATION OF THIS PROCESS EQUIPMENT OPERATION/AIR POLLUTION CONTROL DEVICE.

**RECORDKEEPING.** PLEASE DESCRIBE THE PROPOSED RECORDKEEPING THAT WILL ACCOMPANY THE MONITORING.

**REPORTING.** PLEASE DESCRIBE THE PROPOSED FREQUENCY OF REPORTING OF THE RECORDKEEPING.

**TESTING.** PLEASE DESCRIBE ANY PROPOSED EMISSIONS TESTING FOR THIS PROCESS EQUIPMENT/AIR POLLUTION CONTROL DEVICE.

10. Describe all operating ranges and maintenance procedures required by Manufacturer to maintain warranty  
 This unit is specifically designed for each process and the final design has not been completed. Operating ranges and maintenance procedures will be identified during final design of each unit within the system. The procedures as identified will be followed.

**Attachment L**  
**Emission Unit Data Sheet**  
**(INDIRECT HEAT EXCHANGER)**

**REDACTED**  
**Information Claimed Confidential**  
**6/30/2023**

Control Device ID No. (must match List Form): 8S/1C

**Equipment Information**

1. Manufacturer: [REDACTED]	2. Model No. [REDACTED] Ammonia Unit Serial No. NA
3. Number of units: 1	4. Use Startup Steam Generator
5. Rated Boiler Horsepower: NA hp	6. Boiler Serial No.: NA
7. Date constructed: New	8. Date of last modification and explain: New
9. Maximum design heat input per unit: 5.15 ×10 <sup>6</sup> BTU/hr	10. Peak heat input per unit: 59.46 ×10 <sup>6</sup> BTU/hr
11. Steam produced at maximum design output: NA LB/hr NA psig	12. Projected Operating Schedule: Hours/Day 24 Days/Week 1 Weeks/Year 3
13. Type of firing equipment to be used: <input type="checkbox"/> Pulverized coal <input type="checkbox"/> Spreader stoker <input type="checkbox"/> Oil burners <input type="checkbox"/> Natural Gas Burner <input checked="" type="checkbox"/> Others, specify [REDACTED] Ammonia Combustor	14. Proposed type of burners and orientation: <input type="checkbox"/> Vertical <input type="checkbox"/> Front Wall <input type="checkbox"/> Opposed <input checked="" type="checkbox"/> Tangential <input type="checkbox"/> Others, specify
15. Type of draft: <input checked="" type="checkbox"/> Forced <input type="checkbox"/> Induced	16. Percent of ash retained in furnace: NA %
17. Will flyash be reinjected? <input type="checkbox"/> Yes <input checked="" type="checkbox"/> No	18. Percent of carbon in flyash: NA %

**Stack or Vent Data**

19. Inside diameter or dimensions: NA ft.	20. Gas exit temperature: NA °F
21. Height: NA ft.	22. Stack serves: <input type="checkbox"/> This equipment only <input checked="" type="checkbox"/> Other equipment also (submit type and rating of all other equipment exhausted through this stack or vent)
23. Gas flow rate: NA ft <sup>3</sup> /min	
24. Estimated percent of moisture: NA %	





### Emissions Stream

37. What quantities of pollutants will be emitted from the boiler before controls?

Pollutant	Pounds per Hour lb/hr	grain/ACF	@ °F	PSIA
CO				
Hydrocarbons				
NO <sub>x</sub>	14.50	NA	NA	NA
Pb				
PM <sub>10</sub>				
SO <sub>2</sub>				
VOCs				
Other (specify)				

38. What quantities of pollutants will be emitted from the boiler after controls?

Pollutant	Pounds per Hour lb/hr	grain/ACF	@ °F	PSIA
CO				
Hydrocarbons				
NO <sub>x</sub>	0.145	NA	NA	NA
Pb				
PM <sub>10</sub>				
SO <sub>2</sub>				
VOCs				
Other (specify)				

39. How will waste material from the process and control equipment be disposed of?

There is no waste material generated.

40. Have you completed an *Air Pollution Control Device Sheet(s)* for the control(s) used on this Emission Unit.

41. Have you included the **air pollution rates** on the Emissions Points Data Summary Sheet? Yes

**42. Proposed Monitoring, Recordkeeping, Reporting, and Testing**

Please propose monitoring, recordkeeping, and reporting in order to demonstrate compliance with the proposed operating parameters. Please propose testing in order to demonstrate compliance with the proposed emissions limits.

**MONITORING PLAN:** Please list (1) describe the process parameters and how they were chosen (2) the ranges and how they were established for monitoring to demonstrate compliance with the operation of this process equipment operation or air pollution control device.

None Proposed

**REDACTED**  
**Information Claimed Confidential**  
**6/30/2023**

**TESTING PLAN:** Please describe any proposed emissions testing for this process equipment or air pollution control device.

None Proposed

**RECORDKEEPING:** Please describe the proposed recordkeeping that will accompany the monitoring.

None Proposed

**REPORTING:** Please describe the proposed frequency of reporting of the recordkeeping.

None Proposed

**43. Describe all operating ranges and maintenance procedures required by Manufacturer to maintain warranty.**

██████████ will provide operating and maintenance procedures upon final design of the unit.

**Attachment L**  
**Emission Unit Data Sheet**  
 (INDIRECT HEAT EXCHANGER)

Control Device ID No. (must match List Form): 9S/1C

**Equipment Information**

1. Manufacturer: Haldor Topsoe	2. Model No. Pre-Heater Serial No. NA
3. Number of units: 1	4. Use Pre-heater for Feed Purification
5. Rated Boiler Horsepower: NA hp	6. Boiler Serial No.: NA
7. Date constructed: New	8. Date of last modification and explain: NA
9. Maximum design heat input per unit: 14.3 x10 <sup>6</sup> BTU/hr	10. Peak heat input per unit: 14.7 x10 <sup>6</sup> BTU/hr
11. Steam produced at maximum design output: NA LB/hr NA psig	12. Projected Operating Schedule: Hours/Day 24 Days/Week 7 Weeks/Year 52
13. Type of firing equipment to be used: <input type="checkbox"/> Pulverized coal <input type="checkbox"/> Spreader stoker <input type="checkbox"/> Oil burners <input type="checkbox"/> Natural Gas Burner <input checked="" type="checkbox"/> Others, specify Methane and Hydrogen Burners	14. Proposed type of burners and orientation: <input type="checkbox"/> Vertical <input type="checkbox"/> Front Wall <input checked="" type="checkbox"/> Opposed <input type="checkbox"/> Tangential <input type="checkbox"/> Others, specify
15. Type of draft: <input checked="" type="checkbox"/> Forced <input type="checkbox"/> Induced	16. Percent of ash retained in furnace: NA %
17. Will flyash be reinjected? <input type="checkbox"/> Yes <input checked="" type="checkbox"/> No	18. Percent of carbon in flyash: NA %

**Stack or Vent Data**

19. Inside diameter or dimensions: NA ft.	20. Gas exit temperature: NA °F
21. Height: NA ft.	22. Stack serves: <input type="checkbox"/> This equipment only <input checked="" type="checkbox"/> Other equipment also (submit type and rating of all other equipment exhausted through this stack or vent)
23. Gas flow rate: NA ft <sup>3</sup> /min	
24. Estimated percent of moisture: NA %	



### Emissions Stream

37. What quantities of pollutants will be emitted from the boiler before controls?

Pollutant	Pounds per Hour lb/hr	grain/ACF	@ °F	PSIA
CO	0.01	NA	NA	NA
Hydrocarbons	NA	NA	NA	NA
NO <sub>x</sub>	44.47	NA	NA	NA
Pb	NA	NA	NA	NA
PM <sub>10</sub>	0.01	NA	NA	NA
SO <sub>2</sub>	0.01	NA	NA	NA
VOCs	0.01	NA	NA	NA
Other (specify)				
CH <sub>4</sub>	0.01	NA	NA	NA
CO <sub>2</sub>	2.01	NA	NA	NA

38. What quantities of pollutants will be emitted from the boiler after controls?

Pollutant	Pounds per Hour lb/hr	grain/ACF	@ °F	PSIA
CO	0.01	NA	NA	NA
Hydrocarbons	NA	NA	NA	NA
NO <sub>x</sub>	0.45	NA	NA	NA
Pb	NA	NA	NA	NA
PM <sub>10</sub>	0.01	NA	NA	NA
SO <sub>2</sub>	0.01	NA	NA	NA
VOCs	0.01	NA	NA	NA
Other (specify)				
	0.01	NA	NA	NA
	2.01	NA	NA	NA

39. How will waste material from the process and control equipment be disposed of?

There is no waste material generated.

40. Have you completed an *Air Pollution Control Device Sheet(s)* for the control(s) used on this Emission Unit.

41. Have you included the **air pollution rates** on the Emissions Points Data Summary Sheet? Yes

**42. Proposed Monitoring, Recordkeeping, Reporting, and Testing**

Please propose monitoring, recordkeeping, and reporting in order to demonstrate compliance with the proposed operating parameters. Please propose testing in order to demonstrate compliance with the proposed emissions limits.

**MONITORING PLAN:** Please list (1) describe the process parameters and how they were chosen (2) the ranges and how they were established for monitoring to demonstrate compliance with the operation of this process equipment operation or air pollution control device.

None Proposed

**TESTING PLAN:** Please describe any proposed emissions testing for this process equipment or air pollution control device.

None Proposed

**RECORDKEEPING:** Please describe the proposed recordkeeping that will accompany the monitoring.

None Proposed

**REPORTING:** Please describe the proposed frequency of reporting of the recordkeeping.

None Proposed

**43. Describe all operating ranges and maintenance procedures required by Manufacturer to maintain warranty.**  
Haldor Topsoe will provide operating and maintenance procedures upon final design of the unit.

**Attachment L**  
**Emission Unit Data Sheet**  
(INDIRECT HEAT EXCHANGER)

Control Device ID No. (must match List Form): 10S/1C

**Equipment Information**

1. Manufacturer: Haldor Topsoe	2. Model No. Super Heater Serial No. NA
3. Number of units: 1	4. Use Pre-heater for Feed Purification
5. Rated Boiler Horsepower: NA hp	6. Boiler Serial No.: NA
7. Date constructed: New	8. Date of last modification and explain: NA
9. Maximum design heat input per unit: 13,327 ×10 <sup>6</sup> BTU/hr	10. Peak heat input per unit: ×10 <sup>6</sup> BTU/hr
11. Steam produced at maximum design output: NA LB/hr NA psig	12. Projected Operating Schedule: Hours/Day 24 Days/Week 7 Weeks/Year 52
13. Type of firing equipment to be used: <input type="checkbox"/> Pulverized coal <input type="checkbox"/> Spreader stoker <input type="checkbox"/> Oil burners <input type="checkbox"/> Natural Gas Burner <input checked="" type="checkbox"/> Others, specify Methane and Hydrogen Burners	14. Proposed type of burners and orientation: <input type="checkbox"/> Vertical <input type="checkbox"/> Front Wall <input checked="" type="checkbox"/> Opposed <input type="checkbox"/> Tangential <input type="checkbox"/> Others, specify
15. Type of draft: <input checked="" type="checkbox"/> Forced <input type="checkbox"/> Induced	16. Percent of ash retained in furnace: NA %
17. Will flyash be reinjected? <input type="checkbox"/> Yes <input checked="" type="checkbox"/> No	18. Percent of carbon in flyash: NA %

**Stack or Vent Data**

19. Inside diameter or dimensions: NA ft.	20. Gas exit temperature: NA °F
21. Height: NA ft.	22. Stack serves: <input type="checkbox"/> This equipment only <input checked="" type="checkbox"/> Other equipment also (submit type and rating of all other equipment exhausted through this stack or vent)
23. Gas flow rate: NA ft <sup>3</sup> /min	
24. Estimated percent of moisture: NA %	





### Emissions Stream

37. What quantities of pollutants will be emitted from the boiler before controls?

Pollutant	Pounds per Hour lb/hr	grain/ACF	@ °F	PSIA
CO	0.01	NA	NA	NA
Hydrocarbons	NA	NA	NA	NA
NO <sub>x</sub>	112.62	NA	NA	NA
Pb	NA	NA	NA	NA
PM <sub>10</sub>	0.01	NA	NA	NA
SO <sub>2</sub>	0.01	NA	NA	NA
VOCs	0.01	NA	NA	NA
Other (specify)				
CH <sub>4</sub>	0.01	NA	NA	NA
CO <sub>2</sub>	2.01	NA	NA	NA

38. What quantities of pollutants will be emitted from the boiler after controls?

Pollutant	Pounds per Hour lb/hr	grain/ACF	@ °F	PSIA
CO	0.01	NA	NA	NA
Hydrocarbons	NA	NA	NA	NA
NO <sub>x</sub>	1.14	NA	NA	NA
Pb	NA	NA	NA	NA
PM <sub>10</sub>	0.01	NA	NA	NA
SO <sub>2</sub>	0.01	NA	NA	NA
VOCs	0.01	NA	NA	NA
Other (specify)				
CH <sub>4</sub>	0.01	NA	NA	NA
CO <sub>2</sub>	2.01	NA	NA	NA

39. How will waste material from the process and control equipment be disposed of?

There is no waste material generated.

40. Have you completed an *Air Pollution Control Device Sheet(s)* for the control(s) used on this Emission Unit.

41. Have you included the **air pollution rates** on the Emissions Points Data Summary Sheet?

**42. Proposed Monitoring, Recordkeeping, Reporting, and Testing**

Please propose monitoring, recordkeeping, and reporting in order to demonstrate compliance with the proposed operating parameters. Please propose testing in order to demonstrate compliance with the proposed emissions limits.

**MONITORING PLAN:** Please list (1) describe the process parameters and how they were chosen (2) the ranges and how they were established for monitoring to demonstrate compliance with the operation of this process equipment operation or air pollution control device.

Amount of fuel used.

**TESTING PLAN:** Please describe any proposed emissions testing for this process equipment or air pollution control device.

None Proposed

**RECORDKEEPING:** Please describe the proposed recordkeeping that will accompany the monitoring.

None Proposed

**REPORTING:** Please describe the proposed frequency of reporting of the recordkeeping.

None Proposed

**43. Describe all operating ranges and maintenance procedures required by Manufacturer to maintain warranty. Haldor Topsoe will provide operating and maintenance procedures upon final design of the unit.**

**Attachment L  
EMISSIONS UNIT DATA SHEET  
GENERAL**

To be used for affected sources other than asphalt plants, foundries, incinerators, indirect heat exchangers, and quarries.

Identification Number (as assigned on *Equipment List Form*): 11S

1. Name or type and model of proposed affected source:

Cummins Model C1000N^B  
See attached Generator Set Data Sheet

2. On a separate sheet(s), furnish a sketch(es) of this affected source. If a modification is to be made to this source, clearly indicated the change(s). Provide a narrative description of all features of the affected source which may affect the production of air pollutants.

3. Name(s) and maximum amount of proposed process material(s) charged per hour:

Startup and emergency power generator

4. Name(s) and maximum amount of proposed material(s) produced per hour:

NA

5. Give chemical reactions, if applicable, that will be involved in the generation of air

NA

\* The identification number which appears here must correspond to the air pollution control device identification number appearing on the *List Form*.

6. Combustion Data (if applicable):		
(a) Type and amount in appropriate units of fuel(s) to be burned:		
2,885 MMBtu/hr Methane		
(b) Chemical analysis of proposed fuel(s), excluding coal, including maximum percent sulfur and ash:		
Methane Gas		
(c) Theoretical combustion air requirement (ACF/unit of fuel): See Generator Data Sheets		
@	°F and	psia.
(d) Percent excess air: NA		
(e) Type and BTU/hr of burners and all other firing equipment planned to be used:		
NA		
(f) If coal is proposed as a source of fuel, identify supplier and seams and give sizing of the coal as it will be fired:		
NA		
(g) Proposed maximum design heat input: NA × 10 <sup>6</sup> BTU/hr.		
7. Projected operating schedule: Operated as needed for startup, shutdown and emergencies.		
Hours/Day	24	Days/Week 7
		Weeks/Year 52

8. Projected amount of pollutants that would be emitted from this affected source if no control devices were used: NA

		@	°F and	psia	
a.	NO <sub>x</sub>	31.22	lb/hr	NA	grains/ACF
b.	SO <sub>2</sub>	0.01	lb/hr	NA	grains/ACF
c.	CO	0.38	lb/hr	NA	grains/ACF
d.	PM <sub>10</sub>	0.48	lb/hr	NA	grains/ACF
e.	Hydrocarbons	NA	lb/hr	NA	grains/ACF
f.	VOCs	0.12	lb/hr	NA	grains/ACF
g.	Pb	NA	lb/hr	NA	grains/ACF
h.	Specify other(s)				
	CH <sub>4</sub>	14.28	lb/hr	NA	grains/ACF
	CO <sub>2</sub>	1,083.50		NA	
			lb/hr		grains/ACF
			lb/hr		grains/ACF
			lb/hr		grains/ACF

NOTE: (1) An Air Pollution Control Device Sheet must be completed for any air pollution device(s) used to control emissions from this affected source.

(2) Complete the Emission Points Data Sheet.

9. Proposed Monitoring, Recordkeeping, Reporting, and Testing  
 Please propose monitoring, recordkeeping, and reporting in order to demonstrate compliance with the proposed operating parameters. Please propose testing in order to demonstrate compliance with the proposed emissions limits.

**MONITORING**

Amount of fuel burned.

**RECORDKEEPING**

Amount of fuel burned.

**REPORTING**

None.

**TESTING**

None.

**MONITORING.** PLEASE LIST AND DESCRIBE THE PROCESS PARAMETERS AND RANGES THAT ARE PROPOSED TO BE MONITORED IN ORDER TO DEMONSTRATE COMPLIANCE WITH THE OPERATION OF THIS PROCESS EQUIPMENT OPERATION/AIR POLLUTION CONTROL DEVICE.

**RECORDKEEPING.** PLEASE DESCRIBE THE PROPOSED RECORDKEEPING THAT WILL ACCOMPANY THE MONITORING.

**REPORTING.** PLEASE DESCRIBE THE PROPOSED FREQUENCY OF REPORTING OF THE RECORDKEEPING.

**TESTING.** PLEASE DESCRIBE ANY PROPOSED EMISSIONS TESTING FOR THIS PROCESS EQUIPMENT/AIR POLLUTION CONTROL DEVICE.

10. Describe all operating ranges and maintenance procedures required by Manufacturer to maintain warranty

See Cummins specification sheet and Data Sheet in Appendix 2.

## Attachment L EMISSIONS UNIT DATA SHEET STORAGE TANKS

Provide the following information for each new or modified bulk liquid storage tank as shown on the *Equipment List Form* and other parts of this application. A tank is considered modified if the material to be stored in the tank is different from the existing stored liquid.

IF USING US EPA'S TANKS EMISSION ESTIMATION PROGRAM (AVAILABLE AT [www.epa.gov/tnn/tanks.html](http://www.epa.gov/tnn/tanks.html)), APPLICANT MAY ATTACH THE SUMMARY SHEETS IN LIEU OF COMPLETING SECTIONS III, IV, & V OF THIS FORM. HOWEVER, SECTIONS I, II, AND VI OF THIS FORM MUST BE COMPLETED. US EPA'S AP-42, SECTION 7.1, "ORGANIC LIQUID STORAGE TANKS," MAY ALSO BE USED TO ESTIMATE VOC AND HAP EMISSIONS (<http://www.epa.gov/tnn/chief/>).

### I. GENERAL INFORMATION (required)

1. Bulk Storage Area Name NH3 Tanks	2. Tank Name NH3 Tanks
3. Tank Equipment Identification No. (as assigned on <i>Equipment List Form</i> )	4. Emission Point Identification No. (as assigned on <i>Equipment List Form</i> ) Ammonia is not a regulated pollutant.
5. Date of Commencement of Construction (for existing tanks) New	
6. Type of change <input checked="" type="checkbox"/> New Construction <input type="checkbox"/> New Stored Material <input type="checkbox"/> Other Tank Modification	
7. Description of Tank Modification (if applicable) New – Final design of tanks is not available. Information below is typical for tanks.	
7A. Does the tank have more than one mode of operation? (e.g. Is there more than one product stored in the tank?) <input type="checkbox"/> Yes <input checked="" type="checkbox"/> No	
7B. If YES, explain and identify which mode is covered by this application (Note: A separate form must be completed for each mode). NA	
7C. Provide any limitations on source operation affecting emissions, any work practice standards (e.g. production variation, etc.): NA	

### II. TANK INFORMATION (required)

8. Design Capacity (specify barrels or gallons). Use the internal cross-sectional area multiplied by internal height. 22,337.24 lbs NH3 at -33°C	
9A. Tank Internal Diameter (ft) 100	9B. Tank Internal Height (or Length) (ft) 69
10A. Maximum Liquid Height (ft) 69	10B. Average Liquid Height (ft) 69
11A. Maximum Vapor Space Height (ft) NA	11B. Average Vapor Space Height (ft) NA
12. Nominal Capacity (specify barrels or gallons). This is also known as "working volume" and considers design liquid levels and overflow valve heights. 22,337.24 lbs.	



13A. Maximum annual throughput (gal/yr) 2,125,000 MTPY	13B. Maximum daily throughput (gal/day) 6,000 MTPD
14. Number of Turnovers per year (annual net throughput/maximum tank liquid volume)	
15. Maximum tank fill rate (gal/min)	
16. Tank fill method <input type="checkbox"/> Submerged <input type="checkbox"/> Splash <input type="checkbox"/> Bottom Loading	
17. Complete 17A and 17B for Variable Vapor Space Tank Systems <input type="checkbox"/> Does Not Apply	
17A. Volume Expansion Capacity of System (gal)	17B. Number of transfers into system per year
18. Type of tank (check all that apply): <input type="checkbox"/> Fixed Roof    ___ vertical    ___ horizontal    ___ flat roof    ___ cone roof    ___ dome roof ___ other (describe) <input type="checkbox"/> External Floating Roof    ___ pontoon roof    ___ double deck roof <input type="checkbox"/> Domed External (or Covered) Floating Roof <input type="checkbox"/> Internal Floating Roof    ___ vertical column support    ___ self-supporting <input type="checkbox"/> Variable Vapor Space    ___ lifter roof    ___ diaphragm <input type="checkbox"/> Pressurized    ___ spherical    ___ cylindrical <input type="checkbox"/> Underground <input type="checkbox"/> Other (describe)	

**III. TANK CONSTRUCTION & OPERATION INFORMATION** (optional if providing TANKS Summary Sheets)

19. Tank Shell Construction: <input type="checkbox"/> Riveted <input type="checkbox"/> Gunitite lined <input type="checkbox"/> Epoxy-coated rivets <input type="checkbox"/> Other (describe)		
20A. Shell Color	20B. Roof Color	20C. Year Last Painted
21. Shell Condition (if metal and unlined): <input type="checkbox"/> No Rust <input type="checkbox"/> Light Rust <input type="checkbox"/> Dense Rust <input type="checkbox"/> Not applicable		
22A. Is the tank heated? <input type="checkbox"/> YES <input type="checkbox"/> NO		
22B. If YES, provide the operating temperature (°F)		
22C. If YES, please describe how heat is provided to tank.		
23. Operating Pressure Range (psig):                      to		
24. Complete the following section for <b>Vertical Fixed Roof Tanks</b>		<input type="checkbox"/> Does Not Apply
24A. For dome roof, provide roof radius (ft)		
24B. For cone roof, provide slope (ft/ft)		
25. Complete the following section for <b>Floating Roof Tanks</b>		<input type="checkbox"/> Does Not Apply
25A. Year Internal Floaters Installed:		
25B. Primary Seal Type: <input type="checkbox"/> Metallic (Mechanical) Shoe Seal <input type="checkbox"/> Liquid Mounted Resilient Seal (check one) <input type="checkbox"/> Vapor Mounted Resilient Seal <input type="checkbox"/> Other (describe):		
25C. Is the Floating Roof equipped with a Secondary Seal? <input type="checkbox"/> YES <input type="checkbox"/> NO		
25D. If YES, how is the secondary seal mounted? (check one) <input type="checkbox"/> Shoe <input type="checkbox"/> Rim <input type="checkbox"/> Other (describe):		
25E. Is the Floating Roof equipped with a weather shield? <input type="checkbox"/> YES <input type="checkbox"/> NO		

25F. Describe deck fittings; indicate the number of each type of fitting:		
ACCESS HATCH		
BOLT COVER, GASKETED:	UNBOLTED COVER, GASKETED:	UNBOLTED COVER, UNGASKETED:
AUTOMATIC GAUGE FLOAT WELL		
BOLT COVER, GASKETED:	UNBOLTED COVER, GASKETED:	UNBOLTED COVER, UNGASKETED:
COLUMN WELL		
BUILT-UP COLUMN – SLIDING COVER, GASKETED:	BUILT-UP COLUMN – SLIDING COVER, UNGASKETED:	PIPE COLUMN – FLEXIBLE FABRIC SLEEVE SEAL:
LADDER WELL		
PIP COLUMN – SLIDING COVER, GASKETED:	PIPE COLUMN – SLIDING COVER, UNGASKETED:	
GAUGE-HATCH/SAMPLE PORT		
SLIDING COVER, GASKETED:	SLIDING COVER, UNGASKETED:	
ROOF LEG OR HANGER WELL		
WEIGHTED MECHANICAL ACTUATION, GASKETED:	WEIGHTED MECHANICAL ACTUATION, UNGASKETED:	SAMPLE WELL-SLIT FABRIC SEAL (10% OPEN AREA)
VACUUM BREAKER		
WEIGHTED MECHANICAL ACTUATION, GASKETED:	WEIGHTED MECHANICAL ACTUATION, UNGASKETED:	
RIM VENT		
WEIGHTED MECHANICAL ACTUATION, GASKETED:	WEIGHTED MECHANICAL ACTUATION, UNGASKETED:	
DECK DRAIN (3-INCH DIAMETER)		
OPEN:	90% CLOSED:	
STUB DRAIN		
1-INCH DIAMETER:		
OTHER (DESCRIBE, ATTACH ADDITIONAL PAGES IF NECESSARY)		

26. Complete the following section for Internal Floating Roof Tanks <input type="checkbox"/> Does Not Apply	
26A. Deck Type: <input type="checkbox"/> Bolted <input type="checkbox"/> Welded	
26B. For Bolted decks, provide deck construction:	
26C. Deck seam: <input type="checkbox"/> Continuous sheet construction 5 feet wide <input type="checkbox"/> Continuous sheet construction 6 feet wide <input type="checkbox"/> Continuous sheet construction 7 feet wide <input type="checkbox"/> Continuous sheet construction 5 x 7.5 feet wide <input type="checkbox"/> Continuous sheet construction 5 x 12 feet wide <input type="checkbox"/> Other (describe)	
26D. Deck seam length (ft)	26E. Area of deck (ft <sup>2</sup> )
For column supported tanks:	26G. Diameter of each column:
26F. Number of columns:	

**IV. SITE INFORMANTION** (optional if providing TANKS Summary Sheets)

27. Provide the city and state on which the data in this section are based.
28. Daily Average Ambient Temperature (°F)
29. Annual Average Maximum Temperature (°F)
30. Annual Average Minimum Temperature (°F)
31. Average Wind Speed (miles/hr)
32. Annual Average Solar Insulation Factor (BTU/(ft <sup>2</sup> -day))
33. Atmospheric Pressure (psia)

**V. LIQUID INFORMATION** (optional if providing TANKS Summary Sheets)

34. Average daily temperature range of bulk liquid:			
34A. Minimum (°F)		34B. Maximum (°F)	
35. Average operating pressure range of tank:			
35A. Minimum (psig)		35B. Maximum (psig)	
36A. Minimum Liquid Surface Temperature (°F)		36B. Corresponding Vapor Pressure (psia)	
37A. Average Liquid Surface Temperature (°F)		37B. Corresponding Vapor Pressure (psia)	
38A. Maximum Liquid Surface Temperature (°F)		38B. Corresponding Vapor Pressure (psia)	
39. Provide the following for <u>each</u> liquid or gas to be stored in tank. Add additional pages if necessary.			
39A. Material Name or Composition			
39B. CAS Number			
39C. Liquid Density (lb/gal)			
39D. Liquid Molecular Weight (lb/lb-mole)			
39E. Vapor Molecular Weight (lb/lb-mole)			

Maximum Vapor Pressure 39F. True (psia) 39G. Reid (psia)			
Months Storage per Year 39H. From 39I. To			

**VI. EMISSIONS AND CONTROL DEVICE DATA** (required)

40. Emission Control Devices (check as many as apply):  Does Not Apply

- Carbon Adsorption<sup>1</sup>
- Condenser<sup>1</sup>
- Conservation Vent (psig)
 

Vacuum Setting	Pressure Setting
----------------	------------------
- Emergency Relief Valve (psig)
- Inert Gas Blanket of
- Insulation of Tank with
- Liquid Absorption (scrubber)<sup>1</sup>
- Refrigeration of Tank
- Rupture Disc (psig)
- Vent to Incinerator<sup>1</sup>
- Other<sup>1</sup> (describe):

<sup>1</sup> Complete appropriate Air Pollution Control Device Sheet.

41. Expected Emission Rate (submit Test Data or Calculations here or elsewhere in the application).

Material Name & CAS No.	Breathing Loss (lb/hr)	Working Loss		Annual Loss (lb/yr)	Estimation Method <sup>1</sup>
		Amount	Units		
Ammonia is not a regulated pollutant.					

<sup>1</sup> EPA = EPA Emission Factor, MB = Material Balance, SS = Similar Source, ST = Similar Source Test, Throughput Data, O = Other (specify)

Remember to attach emissions calculations, including TANKS Summary Sheets if applicable.

**ATTACHMENT M**

**AIR POLLUTION  
CONTROL DEVICE(S)**

**Attachment M**  
**Air Pollution Control Device Sheet**  
 (OTHER COLLECTORS)

Control Device ID No. (must match Emission Units Table): 1C

**Equipment Information**

1. Manufacturer: Umicore Model No. DNX CD-139 to LD-939	2. Control Device Name: SCR System (2 Units) Type: SCR
3. Provide diagram(s) of unit describing capture system with duct arrangement and size of duct, air volume, capacity, horsepower of movers. If applicable, state hood face velocity and hood collection efficiency.	
4. On a separate sheet(s) supply all data and calculations used in selecting or designing this collection device.	
5. Provide a scale diagram of the control device showing internal construction.	
6. Submit a schematic and diagram with dimensions and flow rates. See attached information.	
7. Guaranteed minimum collection efficiency for each pollutant collected: 100%	
8. Attached efficiency curve and/or other efficiency information. NA	
9. Design inlet volume: SCFM	10. Capacity:
11. Indicate the liquid flow rate and describe equipment provided to measure pressure drop and flow rate, if any.  See attached information from Umicore. Complete details will be available upon completion of final design.	
12. Attach any additional data including auxiliary equipment and operation details to thoroughly evaluate the control equipment. NA	
13. Description of method of handling the collected material(s) for reuse or disposal.  There is no collected materials.	

**Gas Stream Characteristics**

14. Are halogenated organics present?	<input type="checkbox"/> Yes	<input checked="" type="checkbox"/> No	
Are particulates present?	<input checked="" type="checkbox"/> Yes	<input type="checkbox"/> No	
Are metals present?	<input checked="" type="checkbox"/> Yes	<input type="checkbox"/> No	
15. Inlet Emission stream parameters:	<b>Maximum</b>	<b>Typical</b>	
Pressure (mmHg):	NA	NA	
Heat Content (BTU/scf):	NA	NA	
Oxygen Content (%):	NA	NA	
Moisture Content (%):	NA	NA	
Relative Humidity (%):	NA	NA	

16. Type of pollutant(s) controlled: <input type="checkbox"/> SO <sub>x</sub> <input type="checkbox"/> Odor <input type="checkbox"/> Particulate (type): <input checked="" type="checkbox"/> Other NO <sub>x</sub>				
17. Inlet gas velocity:                      NA                      ft/sec	18. Pollutant specific gravity:			
19. Gas flow into the collector: ACF @                      °F and                      PSIA	20. Gas stream temperature: Inlet:                      °F Outlet:                      °F			
21. Gas flow rate: Design Maximum:                      ACFM Average Expected:                      ACFM	22. Particulate Grain Loading in grains/scf: Inlet: Outlet:			
23. Emission rate of each pollutant (specify) into and out of collector:				
<b>Pollutant</b>	<b>IN Pollutant</b>	<b>Emission Capture Efficiency %</b>	<b>OUT Pollutant</b>	<b>Control Efficiency %</b>
	<b>lb/hr</b>	<b>grains/acf</b>	<b>lb/hr</b>	<b>grains/acf</b>
A				
B				
C				
D				
E				
24. Dimensions of stack:                      Height                      ft.                      Diameter                      ft.				
25. Supply a curve showing proposed collection efficiency versus gas volume from 25 to 130 percent of design rating of collector.				

**Particulate Distribution**

26. Complete the table:	<b>Particle Size Distribution at Inlet to Collector</b>	<b>Fraction Efficiency of Collector</b>
<b>Particulate Size Range (microns)</b>	<b>Weight % for Size Range</b>	<b>Weight % for Size Range</b>
0 – 2		
2 – 4		
4 – 6	See attached Umicore document.	
6 – 8		
8 – 10		
10 – 12		
12 – 16		
16 – 20		
20 – 30		
30 – 40		
40 – 50		
50 – 60		
60 – 70		
70 – 80		
80 – 90		
90 – 100		
>100		

27. Describe any air pollution control device inlet and outlet gas conditioning processes (e.g., gas cooling, gas reheating, gas humidification):

28. Describe the collection material disposal system:

29. Have you included **Other Collectores Control Device** in the Emissions Points Data Summary Sheet?

30. **Proposed Monitoring, Recordkeeping, Reporting, and Testing**  
Please propose monitoring, recordkeeping, and reporting in order to demonstrate compliance with the proposed operating parameters. Please propose testing in order to demonstrate compliance with the proposed emissions limits.

MONITORING:  
Amount of ammonia used for NOx control.

RECORDKEEPING:  
Amount of ammonia used for NOx control.

REPORTING:  
None.

TESTING:  
None.

MONITORING: Please list and describe the process parameters and ranges that are proposed to be monitored in order to demonstrate compliance with the operation of this process equipment or air control device.  
RECORDKEEPING: Please describe the proposed recordkeeping that will accompany the monitoring.  
REPORTING: Please describe any proposed emissions testing for this process equipment on air pollution control device.  
TESTING: Please describe any proposed emissions testing for this process equipment on air pollution control device.

31. Manufacturer's Guaranteed Control Efficiency for each air pollutant.  
99%

32. Manufacturer's Guaranteed Control Efficiency for each air pollutant.  
99%

33. Describe all operating ranges and maintenance procedures required by Manufacturer to maintain warranty. The SCR system selected will meet the operating conditions of the emission sources.



To whom it may concern,

With a reactor in series design, ~99% NO<sub>x</sub> removal is achievable with currently available SCR catalysts. Please see below basic illustration of such a layout.

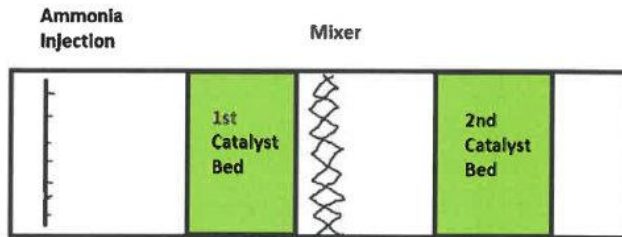

Product Sheet



### SCR DeNO<sub>x</sub> catalyst DNX<sup>®</sup>-series DNX LD-139 to LD-939

**Description**

The DNX LD-139 to LD-939 catalyst series is a fiber reinforced Vanadium-Tungsten-Titanium catalyst. The catalyst is available in a version with 0.4 mm wall.

**Application areas**

The DNX LD-139 to LD-939 catalyst is suitable for operation in a low dust environment, and it is typically used in SCR installations with minor amounts of particles in the flue gas. The catalyst also poses a high activity for dioxin removal.

**Physical and chemical properties**

<b>Physical properties</b>	
Wall thickness, mm	0.4
Channel hydraulic diameter, mm	3.4
Cell pitch, mm	4.1
Plate pitch, mm	4.1
Cell density, CPSI	30
Specific area m <sup>2</sup> /m <sup>3</sup>	880
Open area (void), %	76
Leading edge reinforcement	Yes
<b>Chemical composition</b>	
Vanadium pentoxide, %	0.1 - 4
Tungsten trioxide, %	2 - 8
Silicon dioxide, %	0 - 4
Titanium dioxide, %	73 - 83
Fibers, %	12 - 18
<b>Element sizes</b>	
Element cross section including metal frame, mm x mm	466 x 466
Element height, mm	322 / 342 / 572 / 612
Net catalyst depth, mm	250 / 270 / 500 / 640





**44. Proposed Monitoring, Recordkeeping, Reporting, and Testing**

Please propose monitoring, recordkeeping, and reporting in order to demonstrate compliance with the proposed operating parameters. Please propose testing in order to demonstrate compliance with the proposed emissions limits.

**MONITORING:**

Thermocouple monitoring to determine flare operation.

**RECORDKEEPING:**

Flare startup, shutdown, and steady state operating hours.

**REPORTING:**

None proposed.

**TESTING:**

None proposed.

**MONITORING:**

Please list and describe the process parameters and ranges that are proposed to be monitored in order to demonstrate compliance with the operation of this process equipment or air control device.

**RECORDKEEPING:**

Please describe the proposed recordkeeping that will accompany the monitoring.

**REPORTING:**

Please describe any proposed emissions testing for this process equipment on air pollution control device.

**TESTING:**

Please describe any proposed emissions testing for this process equipment on air pollution control device.

**45. Manufacturer's Guaranteed Capture Efficiency for each air pollutant.**

100%

**46. Manufacturer's Guaranteed Control Efficiency for each air pollutant.**

98.5%

**47. Describe all operating ranges and maintenance procedures required by Manufacturer to maintain warranty.**

Operating ranges and maintenance procedures will be identified during final design and/or purchase of the flare system. The procedures provided by the manufacturer will be followed.





**44. Proposed Monitoring, Recordkeeping, Reporting, and Testing**

Please propose monitoring, recordkeeping, and reporting in order to demonstrate compliance with the proposed operating parameters. Please propose testing in order to demonstrate compliance with the proposed emissions limits.

**MONITORING:**  
Thermocouple monitoring to determine flare operation.

**RECORDKEEPING:**  
Flare startup, shutdown, and steady state operating hours.

**REPORTING:**  
None proposed.

**TESTING:**  
None proposed.

**MONITORING:** Please list and describe the process parameters and ranges that are proposed to be monitored in order to demonstrate compliance with the operation of this process equipment or air control device.  
**RECORDKEEPING:** Please describe the proposed recordkeeping that will accompany the monitoring.  
**REPORTING:** Please describe any proposed emissions testing for this process equipment on air pollution control device.  
**TESTING:** Please describe any proposed emissions testing for this process equipment on air pollution control device.

**45. Manufacturer's Guaranteed Capture Efficiency for each air pollutant.**

100%

**46. Manufacturer's Guaranteed Control Efficiency for each air pollutant.**

98.5%

**47. Describe all operating ranges and maintenance procedures required by Manufacturer to maintain warranty.**

Operating ranges and maintenance procedures will be identified during final design and/or purchase of the flare system. The procedures provided by the manufacturer will be followed.

**ATTACHMENT N**

**SUPPORTING EMISSIONS  
CALCULATIONS**



**Yearly Emissions By Source**

<b>Boiler</b>	
Emission	tpy
NOx	0.01

<b>Generator</b>	
NOx	1.57
CO	0.02
CO2	54.18
SO2	0.01
CH4	0.72
VOC	0.01
PM	0.03
PM10	0.03
PM2.5	0.03

<b>Heaters</b>	
PM	0.02
PM10	0.02
PM2.5	0.02
CO	0.30
CO2	409.00
SO2	0.02
CH4	0.02
VOC	0.02
NOx	6.69

<b>Total Flares</b>	
CH4	249.76
CO	19.68
CO2	1181.44
NH3	0.54
NOx	54.78

<b>Total Fugitives</b>	
CO	1.47
CO2	5.79
CH4	0.20
NH3	4.73

**Total Potential to Emit (TPY)**

PM	0.05
PM10	0.05
PM2.5	0.05
CO	21.47
CO2	1650.41
SO2	0.03
CH4	250.71
VOC	0.03
NOx	63.05
NH3	5.27

**REDACTED**  
**Information Claimed Confidential**  
**6/30/2023**

Boiler (NH3 Fired)

100 ppm NOx initial uncontrolled (first hour)  
60 ppm NOx steady state uncontrolled

Cummings generator  
9.85 mmBtu/hr

Ammonia Feed Rate  
6,100 kg/h 13,448 lb/h  
Uncontrolled NOx  
143 mol NOx/h 6,579 g NOx/h  
27.77 mol NOx/mmBtu  
1,277.43 g NOx/mmBtu  
2.82 lb NOx/mmBtu  
167.45 lb NOx/startup

Ammonia Energy (liquid -33C)  
382.8 Btu/lb

Constants and Conversion Used  
35.3147 NM3 to SCF  
2.20462 lb/kg  
0.0022 g/lb  
325 Btu H2/SCF H2  
8500 operating hours per year  
2204.62 lb/metric ton  
0.1124 Btu/SCF per kcal/Nm3  
1.836 kg CO2(g)/Nm3 CO2 (g)  
1.429 kg O2/Nm3 O2  
1.251 kg N2 (g)/Nm3 N2 (g)  
4850 kg H2O (g)/Nm3 H2O (g)  
44.0095 g/mol CO2  
31.9988 g/mol O2  
28.014 g/mol N2  
20.027 g/mol H2O  
46.0055 g/mol NO2 (surrogate for NOx)  
0.05189 kg CO2 (g)/SCF CO2 (g)  
0.03756 kg O2 (g)/SCF O2 (g)  
0.03286 kg N2 (g)/SCF N2 (g)  
0.021413 kg H2O (g)/SCF H2O (g)

Startup and Emergency Generator

Startup and Emergency Generator			
AP-42 factors and results for 1 hour @ 100%			
		lbs/hr	ton/yr*
NOx	3.17 lb/mmBtu	31.22	1.57
CO	0.0386 lb/mmBtu	0.38	0.02
CO2	110 lb/mmBtu	1083.50	54.18
SO2	0.000588 lb/mmBtu	0.01	0.01
TOC	1.64 lb/mmBtu	16.15	0.81
CH4	1.45 lb/mmBtu	14.28	0.72
VOC	0.012 lb/mmBtu	0.12	0.01
PM/PM10/PM2.5	0.04831 lb/mmBtu	0.48	0.03

\*Operating Hours = 100

UnControlled						
Time	Feed Rate	Ammonia Consumed	NOx mol	NOx kg	NOx lb	
0 hr	0.0%	- lb	0 mmBtu	-	-	-
1 hr	50.0%	6,724 lb	2.57 mmBtu	71.47	3.29	7.25
2 hr	100.0%	13,448 lb	5.15 mmBtu	142.94	6.58	14.50
3 hr	100.0%	13,448 lb	5.15 mmBtu	142.94	6.58	14.50
4 hr	100.0%	13,448 lb	5.15 mmBtu	142.94	6.58	14.50
5 hr	100.0%	13,448 lb	5.15 mmBtu	142.94	6.58	14.50
6 hr	100.0%	13,448 lb	5.15 mmBtu	142.94	6.58	14.50
7 hr	100.0%	13,448 lb	5.15 mmBtu	142.94	6.58	14.50
8 hr	100.0%	13,448 lb	5.15 mmBtu	142.94	6.58	14.50
9 hr	100.0%	13,448 lb	5.15 mmBtu	142.94	6.58	14.50
10 hr	100.0%	13,448 lb	5.15 mmBtu	142.94	6.58	14.50
11 hr	80.0%	10,759 lb	4.12 mmBtu	114.35	5.26	11.60
12 hr	75.0%	10,086 lb	3.86 mmBtu	107.21	4.93	10.87
13 hr	50.0%	6,724 lb	2.57 mmBtu	71.47	3.29	7.25
14 hr	0.0%	- lb	0.00 mmBtu	-	-	-
			59.46 mmBtu		167.45 NOx lb	
						Control 99% reduction 1.67 NOx lb

Startups per Year = 3  
Hours per Startup = 14

Emissions for Boiler			
Uncontrolled		Controlled	
lb/hr	ton/yr	lb/hr	ton/yr
14.50	0.25	0.145	0.01

REDACTED  
Information Claimed Confidential

### 5.4.5 Reformer flue gas

Quantity, Nm <sup>3</sup> /h	210,350
Temperature, °C	140
CO <sub>2</sub> content, mol-% (dry)	0.54
NOx content, mol ppm at 3% O <sub>2</sub> , estimated	<40

H2 feed H 201	45,130 Nm <sup>3</sup> H2/h	28.3% Emission Assignmnet			
H2 feed H 202	114376 Nm <sup>3</sup> H2/h	71.7% Emission Assignmnet			
<b>total H2 flow</b>	<b>159,506 Nm<sup>3</sup> H2/h</b>				
Controlled NOx/yr	6.67 short ton	28.3%	H201	1.89 NOx ton/yr	
		71.7%	H202	4.78 NOx ton/yr	

Wet Flue Gas Flow					
3,000mtpd	210,350.00	m <sup>3</sup> /hr		Operating Hours	8,500
6,000mtpd	420,700.00	m <sup>3</sup> /hr			Hours/Year
22.4nm <sup>3</sup> /mole	18,781.25	kgmole/hr			
	450,750.00	kgmole/day			
	164,523,750	kgmole/yr			

Prorated Flue Gas Flow					
H2 feed H 201	45,130 Nm <sup>3</sup> H2/h		28.3%	Emission Contribution	
H2 feed H 202	114376 Nm <sup>3</sup> H2/h		71.7%	Emission Contribution	
<b>total H2 flow</b>	<b>159,506 Nm<sup>3</sup> H2/h</b>				

NOx Flow Before SCR					
NOx 40ppmv	6,580.95	kgmole NOx/yr			
NOx mol wt g	46		302.72	NOx metric tpy before SCR	
			667.20	NOx Short ton/yr	
H201 portion 28.3%			188.78	NOx Short ton/yr	44.42 lb/hr
H202 portion 71.7%			478.43	NOx Short ton/yr	112.57 lb/hr

NOx Exit SCR					
SCR reduction %	99%				
			3.03	NOx metric TPY exit SCR	
			6.67	NOx Short tons/yr	
H201 portion 28.3%			1.89	NOx Short tons/yr	0.44 lb/hr
H202 portion 71.7%			4.78	NOx Short tons/yr	1.13 lb/hr

Emissions from Pre-Heater H201				
Type	Uncontrolled		Controlled	
	lb/hr	ton/yr	lb/hr	ton/yr
PM	0.01	0.01	0.01	0.01
PM10	0.01	0.01	0.01	0.01
PM2.5	0.01	0.01	0.01	0.01
CO	0.01	0.15	0.01	0.15
CO2	2.01	204.50	2.01	204.50
SO2	0.01	0.01	0.01	0.01
CH4	0.01	0.01	0.01	0.01
VOC	0.01	0.01	0.01	0.01
NOx	44.47	188.79	0.45	1.90

Emissions from Super Heater H202				
Type	Uncontrolled		Controlled	
	lb/hr	ton/yr	lb/hr	ton/yr
PM	0.01	0.01	0.01	0.01
PM10	0.01	0.01	0.01	0.01
PM2.5	0.01	0.01	0.01	0.01
CO	0.01	0.15	0.01	0.15
CO2	2.01	204.50	2.01	204.50
SO2	0.01	0.01	0.01	0.01
CH4	0.01	0.01	0.01	0.01
VOC	0.01	0.01	0.01	0.01
NOx	112.62	478.44	1.14	4.79

**Methane Trace Gas for Flame Detection**

From methann co-feed			
590	Nm3/h	Methane feed with H2 fuel	979.98 Btu/SCF methane fuel
16.7	SCF/h	Methane feed with H2 fuel	3.41 mmSCF/yr
16,372	Btu/h	Methane feed with H2 fuel	139.17 mmBtu/yr methane fuel
AP 42 Factors			
100	Uncontrolled Nox factor	lb/mmSCF	84 CO uncontrolled lb/mmSCF
50	Controlled low Nox burners	lb/mmSCF	120,000 CO2 uncontrolled lb/mmSCF
7.6	PM Total	lb/mmSCF	0.6 SO2 uncontrolled lb/mmSCF
11	TOC uncontrolled	lb/mmSCF	2.3 CH4 uncontrolled lb/mmSCF
5.5	VOC uncontrolled	lb/mmSCF	
NOx uncontrolled	341	lb/yr	Operating Hours 8,500 Hours/Year
NOx controlled	3	lb/yr	99% reduction per vendor
PM	0.02	lb/yr	
TOC	37	lb/yr	
CO	286	lb/yr	
CO2	408,985	lb/yr	
SO2	2	lb/yr	
CH4	8	lb/yr	
VOC	19	lb/yr	

Constants and Conversion Used	
35.3147	NM3 to SCF
2.20462	lb/kg
0.0022	g/lb
325	Btu H2/SCF H2
8500	operating hours per year
2204.62	lb/metric ton
0.1124	Btu/SCF per kcal/Nm3
1.836	kg CO2(g)/Nm <sup>3</sup> CO2 (g)
1.429	kgO2/Nm <sup>3</sup> O2
1.251	kgN2 (g)/Nm <sup>3</sup> N2 (g)
4850	kg H2O (g)/Nm <sup>3</sup> H2O (g)
44.0095	g/mol CO2
31.9988	g/mol O2
28.014	g/mol N2
20.027	g/mol H2O
46.0055	g/mol NO2 (surgate for NOx)
0.05189	kg CO2 (g)/SCF CO2 (g)
0.03756	kg O2 (g)/SCF O2 (g)
0.03286	kg N2 (g)/SCF N2 (g)
0.021413	kg H2O (g)/SCF H2O (g)

Emissions from Co-Feed Signal Methane Fuel				
Type	Uncontrolled		Controlled	
	lb/hr	ton/yr	lb/hr	ton/yr
PM	0.01	0.01	0.01	0.01
PM10	0.01	0.01	0.01	0.01
PM2.5	0.01	0.01	0.01	0.01
CO	0.01	0.15	0.01	0.15
CO2	2.01	204.50	2.01	204.50
SO2	0.01	0.01	0.01	0.01
CH4	0.01	0.01	0.01	0.01
VOC	0.01	0.01	0.01	0.01
NOx	0.05	0.01	0.01	0.01

Fugitive Leaks

Fugitive Leaks (Based on Lines 2015,2102,2160, 3745, and 7170)

Maximum (Mole %)	
CO	7.2
CO2	24.4
CH4	1.0

Source Type	Number of Sources	Emission Factor(1) (kg/hr/source)	TOC Emissions (lb/hr)	TOC Emissions (ton/yr)	Uncontrolled		Control Efficiency (%)	Controlled	
					CO Emissions (lb/hr)	CO Emissions (ton/yr)		CO Emissions (lb/hr)	CO Emissions (ton/yr)
Valves	415	0.000131	0.119853	0.524956	0.008677	0.038007	0	0.008677	0.038007
Pressure Relief Valves	40	0.0447	3.941825	17.265193	0.285388	1.250000	0	0.285388	1.250000
Connectors (Flanges)	917	0.0000810	0.163751	0.717230	0.011856	0.051927	0	0.011856	0.051927
Compressor Seals	2	0.089	0.394182	1.726519	0.028539	0.125000	0	0.028539	0.125000
Light Liquid Pumps	0	0.0019	0.000000	0.000000	0.000000	0.000000	0	0.000000	0.000000
Sample Connections (2)	0	0.0150	0.000000	0.000000	0.000000	0.000000	0	0.000000	0.000000
<b>Emissions</b>					0.33	1.46		0.33	1.46

Source Type	Number of Sources	Emission Factor(1) (kg/hr/source)	TOC Emissions (lb/hr)	TOC Emissions (ton/yr)	Uncontrolled		Control Efficiency (%)	Controlled	
					CO2 Emissions (lb/hr)	CO2 Emissions (ton/yr)		CO2 Emissions (lb/hr)	CO2 Emissions (ton/yr)
Valves	415	0.000131	0.119853	0.524956	0.029208	0.127932	0	0.029208	0.127932
Pressure Relief Valves	40	0.0447	3.941825	17.265193	0.960623	4.207527	0	0.960623	4.207527
Connectors (Flanges)	917	0.0000810	0.163751	0.717230	0.039906	0.174789	0	0.039906	0.174789
Compressor Seals	2	0.089	0.394182	1.726519	0.096062	0.420753	0	0.096062	0.420753
Light Liquid Pumps	0	0.0019	0.000000	0.000000	0.000000	0.000000	0	0.000000	0.000000
Sample Connections (2)	0	0.0150	0.000000	0.000000	0.000000	0.000000	0	0.000000	0.000000
<b>Emissions</b>					1.13	4.93		1.13	4.93

Source Type	Number of Sources	Emission Factor(1) (kg/hr/source)	TOC Emissions (lb/hr)	TOC Emissions (ton/yr)	Uncontrolled		Control Efficiency (%)	Controlled	
					CH4 Emissions (lb/hr)	CH4 Emissions (ton/yr)		CH4 Emissions (lb/hr)	CH4 Emissions (ton/yr)
Valves	415	0.000131	0.119853	0.524956	0.001211	0.005302	0	0.001211	0.005302
Pressure Relief Valves	40	0.0447	3.941825	17.265193	0.039812	0.174378	0	0.039812	0.174378
Connectors (Flanges)	917	0.0000810	0.163751	0.717230	0.001654	0.007244	0	0.001654	0.007244
Compressor Seals	2	0.089	0.394182	1.726519	0.003981	0.017438	0	0.003981	0.017438
Light Liquid Pumps	0	0.0019	0.000000	0.000000	0.000000	0.000000	0	0.000000	0.000000
Sample Connections (2)	0	0.0150	0.000000	0.000000	0.000000	0.000000	0	0.000000	0.000000
<b>Emissions</b>					0.05	0.20		0.05	0.20

1. AP42, Chapter 5, Protocol for Equipment Leak Emission Estimates, Table 2-1.  
lb/kg = 2.2046

Fugitive Leaks (Based on Lines 3745)

Maximum (Mole %)	
CO	0.01
CO2	99.23

Source Type	Number of Sources	Emission Factor(1) (kg/hr/source)	TOC Emissions (lb/hr)	TOC Emissions (ton/yr)	Uncontrolled		Control Efficiency (%)	Controlled	
					CO Emissions (lb/hr)	CO Emissions (ton/yr)		CO Emissions (lb/hr)	CO Emissions (ton/yr)
Valves	2	0.000131	0.000578	0.002530	0.000000	0.000000	0	0.000000	0.000000
Pressure Relief Valves	0	0.0447	0.000000	0.000000	0.000000	0.000000	0	0.000000	0.000000
Connectors (Flanges)	4	0.0000810	0.000714	0.003129	0.000000	0.000000	0	0.000000	0.000000
Compressor Seals	1	0.089	0.197091	0.863260	0.000020	0.000086	0	0.000020	0.000086
Light Liquid Pumps	0	0.0019	0.000000	0.000000	0.000000	0.000000	0	0.000000	0.000000
Sample Connections (2)	0	0.0150	0.000000	0.000000	0.000000	0.000000	0	0.000000	0.000000
<b>Emissions</b>					0.00	0.00		0.00	0.00

Source Type	Number of Sources	Emission Factor(1) (kg/hr/source)	TOC Emissions (lb/hr)	TOC Emissions (ton/yr)	Uncontrolled		Control Efficiency (%)	Controlled	
					CO2 Emissions (lb/hr)	CO2 Emissions (ton/yr)		CO2 Emissions (lb/hr)	CO2 Emissions (ton/yr)
Valves	2	0.000131	0.000578	0.002530	0.000573	0.002510	0	0.000573	0.002510
Pressure Relief Valves	0	0.0447	0.000000	0.000000	0.000000	0.000000	0	0.000000	0.000000
Connectors (Flanges)	4	0.0000810	0.000714	0.003129	0.000709	0.003105	0	0.000709	0.003105
Compressor Seals	1	0.089	0.197091	0.863260	0.195574	0.856613	0	0.195574	0.856613
Light Liquid Pumps	0	0.0019	0.000000	0.000000	0.000000	0.000000	0	0.000000	0.000000
Sample Connections (2)	0	0.0150	0.000000	0.000000	0.000000	0.000000	0	0.000000	0.000000
<b>Emissions</b>					0.20	0.86		0.20	0.86

1. AP42, Chapter 5, Protocol for Equipment Leak Emission Estimates, Table 2-1.  
lb/kg = 2.2046

Fugitive Leaks (Based on Lines 2440)

Maximum (Mole %)	
NH3	2.14

Source Type	Number of Sources	Emission Factor(1) (kg/hr/source)	TOC Emissions (lb/hr)	TOC Emissions (ton/yr)	Uncontrolled		Control Efficiency (%)	Controlled	
					NH3 Emissions (lb/hr)	NH3 Emissions (ton/yr)		NH3 Emissions (lb/hr)	NH3 Emissions (ton/yr)
Valves	118	0.000131	0.034079	0.149265	0.000729	0.003194	0	0.000729	0.003194
Pressure Relief Valves	13	0.0447	1.281093	5.611188	0.027415	0.120079	0	0.027415	0.120079
Connectors (Flanges)	249	0.0000810	0.044465	0.194755	0.000952	0.004168	0	0.000952	0.004168
Compressor Seals	2	0.089	0.394182	1.726519	0.008436	0.036948	0	0.008436	0.036948
Light Liquid Pumps	0	0.0019	0.000000	0.000000	0.000000	0.000000	0	0.000000	0.000000
Sample Connections (2)	0	0.0150	0.000000	0.000000	0.000000	0.000000	0	0.000000	0.000000
<b>Emissions</b>					0.04	0.16		0.04	0.16

Fugitive Leaks (Based on Lines 4600)

Maximum (Mole %)	
NH3	100.00

Source Type	Number of Sources	Emission Factor(1) (kg/hr/source)	TOC Emissions (lb/hr)	TOC Emissions (ton/yr)	Uncontrolled		Control Efficiency (%)	Controlled	
					NH3 Emissions (lb/hr)	NH3 Emissions (ton/yr)		NH3 Emissions (lb/hr)	NH3 Emissions (ton/yr)
Valves	84	0.000131	0.024259	0.106256	0.024259	0.106256	0	0.024259	0.106256
Pressure Relief Valves	8	0.0447	0.788365	3.453039	0.788365	3.453039	0	0.788365	3.453039
Connectors (Flanges)	178	0.0000810	0.031786	0.139222	0.031786	0.139222	0	0.031786	0.139222
Compressor Seals	1	0.089	0.197091	0.863260	0.197091	0.863260	0	0.197091	0.863260
Light Liquid Pumps	0	0.0019	0.000000	0.000000	0.000000	0.000000	0	0.000000	0.000000
Sample Connections (2)	0	0.0150	0.000000	0.000000	0.000000	0.000000	0	0.000000	0.000000
<b>Emissions</b>					1.04	4.56		1.04	4.56

1. AP42, Chapter 5, Protocol for Equipment Leak Emission Estimates, Table 2-1.  
lb/kg = 2.2046

	Total Fugitives			
	Uncontrolled		Controlled	
	lb/hr	ton/yr	lb/hr	ton/yr
CO	0.33	1.47	0.33	1.47
CO2	1.32	5.79	1.32	5.79
CH4	0.05	0.20	0.05	0.20
NH3	1.08	4.73	1.08	4.73

Flare Emissions for Gas Flare and NH3 Flare

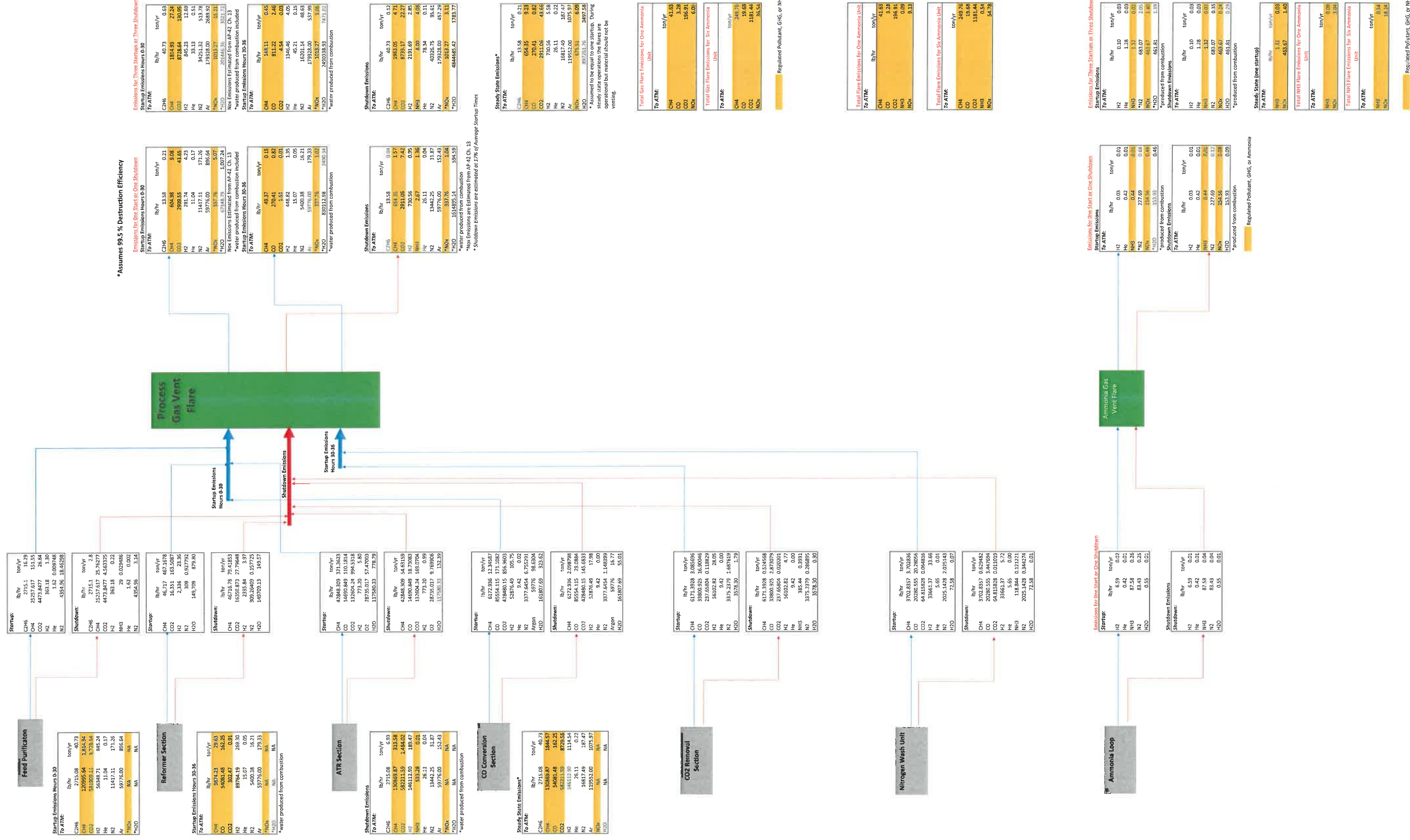

\*Assumes 99.5 % Destruction Efficiency

Emissions for One Start or One Shutdown

Emissions for Three Startups or Three Shutdowns

Startup Emissions Hours 0-30

To ATM:	lb/hr	ton/yr
CH <sub>4</sub>	40.73	0.63
CO	1814.53	27.24
CO <sub>2</sub>	8728.64	130.95
H <sub>2</sub>	845.23	12.69
He	39.33	0.51
N <sub>2</sub>	17938.00	268.92
Ar	1031.27	15.21
H <sub>2</sub> O	20146.36	303.72

Nox Emissions Estimated from AP-42, Ch. 13

\*water produced from combustion included

Startup Emissions Hours 30-36

To ATM:	lb/hr	ton/yr
CH <sub>4</sub>	811.22	2.46
CO	4.54	0.03
CO <sub>2</sub>	1346.46	4.05
H <sub>2</sub>	16201.44	48.63
He	17938.00	537.89
Ar	1031.27	3.04
H <sub>2</sub> O	2490338.93	7471.02

\*water produced from combustion

Shutdown Emissions

To ATM:	lb/hr	ton/yr
CH <sub>4</sub>	40.73	0.32
CO	1963.05	4.71
CO <sub>2</sub>	7933.17	22.27
H <sub>2</sub>	2191.69	2.85
NH <sub>3</sub>	8.00	4.08
He	78.34	0.11
N <sub>2</sub>	4037.59	6.49
Ar	17938.00	457.29
H <sub>2</sub> O	4844485.42	1783.77

\*water produced from combustion

Nox Emissions Estimated from AP-42, Ch. 13

\*Shutdown Emissions are estimated at 1.7% of Average Startup Times

Steady State Emissions\*

To ATM:	lb/hr	ton/yr
CH <sub>4</sub>	634.58	0.32
CO	270.41	0.82
CO <sub>2</sub>	2911.05	43.66
H <sub>2</sub>	720.56	5.58
He	26.11	0.22
N <sub>2</sub>	16817.49	387.47
Ar	11793.93	106.97
H <sub>2</sub> O	897201.76	3497.58

\* Assumed to be equal to one startup. During steady state operations the flares are operational but material should not be venting.

Total Gas Flare Emissions for One Ammonia Unit

To ATM:	Unit
CH <sub>4</sub>	41.63
CO	3.28
CO <sub>2</sub>	156.91
NH <sub>3</sub>	6.01

Total Gas Flare Emissions for Six Ammonia Units

To ATM:	ton/yr
CH <sub>4</sub>	248.79
CO	19.69
CO <sub>2</sub>	1181.44
NH <sub>3</sub>	36.54

Regulated Pollutant, GHG, or NH3

Total Flare Emissions for One Ammonia Unit

To ATM:	lb/hr	ton/yr
CH <sub>4</sub>	41.68	0.63
CO	1814.53	27.24
CO <sub>2</sub>	8728.64	130.95
H <sub>2</sub>	845.23	12.69
He	39.33	0.51
N <sub>2</sub>	17938.00	268.92
Ar	1031.27	15.21
H <sub>2</sub> O	20146.36	303.72

Total Flare Emissions for Six Ammonia Units

To ATM:	ton/yr
CH <sub>4</sub>	249.76
CO	19.69
CO <sub>2</sub>	1181.44
NH <sub>3</sub>	36.54
H <sub>2</sub> O	547.28

Emissions for One Start or One Shutdown

Emissions for Three Startups or Three Shutdowns

Startup Emissions

To ATM:	lb/hr	ton/yr
H <sub>2</sub>	0.10	0.03
He	1.28	0.03
NH <sub>3</sub>	1.72	0.01
N <sub>2</sub>	683.07	2.05
NO <sub>x</sub>	463.67	1.41
H <sub>2</sub> O	463.67	1.41

\*Produced from combustion

Shutdown Emissions

To ATM:	lb/hr	ton/yr
H <sub>2</sub>	0.10	0.03
He	1.28	0.03
NH <sub>3</sub>	1.72	0.01
N <sub>2</sub>	683.07	0.35
NO <sub>x</sub>	463.67	0.24
H <sub>2</sub> O	463.67	0.24

\*Produced from combustion

Steady State (one startup)

To ATM:	lb/hr	ton/yr
NH <sub>3</sub>	1.72	0.03
NO <sub>x</sub>	463.67	1.41

Total NH3 Flare Emissions for One Ammonia Unit

To ATM:	Unit
NH <sub>3</sub>	0.01
NO <sub>x</sub>	0.01

Total NH3 Flare Emissions for Six Ammonia Units

To ATM:	ton/yr
NH <sub>3</sub>	0.18
NO <sub>x</sub>	1.84

Regulated Pollutant, GHG, or NH3

**REDACTED**  
**ENTIRE PAGE CLAIMED**  
**CONFIDENTIAL – 6/30/2023**



Used UniSim to simulate process vent to a burner, UniSim doesn't do an adequate job of predicting NOx or CO but gives a good representative heat output from the burner.  
 Will use this along with the following from EPA guidance for NOx calculations from AP-42 Chapter 13.  
 Reference document found here: chrome-extension://efaidnbmninnnigppcggcliefndmka/https://www3.epa.gov/ttnchie1/ap42/ch13/final/c13a05.pdf

Chose Startup Scenario #1 as the basis for determining heat output of flare and made that basis for worst case.

Table 13.5-1 (English Units). EMISSION FACTORS FOR FLARE OPERATIONS<sup>a</sup>  
 EMISSION FACTOR RATING: B

Component	Emission Factor (lb/10 <sup>6</sup> Btu)
Total hydrocarbons <sup>b</sup>	0.14
Carbon monoxide	0.37
Nitrogen oxides	0.068
Soot <sup>c</sup>	0 - 274

<sup>a</sup> Reference 1. Based on tests using crude propylene containing 80% propylene and 20% propane.  
<sup>b</sup> Measured as methane equivalent.  
<sup>c</sup> Soot is concentration values: nonsmoking flares, 0 micrograms per liter (µg/L); lightly smoking flares, 40 µg/L; average smoking flares, 177 µg/L; and heavily smoking flares, 274 µg/L.

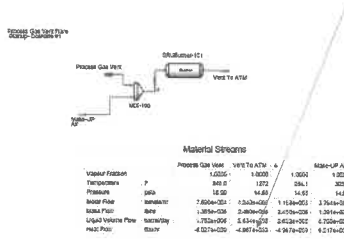

4.967E+09 btu/hr      4967 btu 10<sup>6</sup>/hr

Nox produced at 0.068 Emission Factor  
 337.756 lb/hr

Assume 36 Hour Startup, Quick Estimate  
 10,808.19 lbs/ Startup

**REDACTED**  
**ENTIRE PAGE CLAIMED**  
**CONFIDENTIAL – 6/30/2023**

**REDACTED**  
**ENTIRE PAGE CLAIMED**  
**CONFIDENTIAL – 6/30/2023**

**REDACTED**  
**ENTIRE PAGE CLAIMED**  
**CONFIDENTIAL – 6/30/2023**

**REDACTED**  
**ENTIRE PAGE CLAIMED**  
**CONFIDENTIAL – 6/30/2023**

**REDACTED**  
**ENTIRE PAGE CLAIMED**  
**CONFIDENTIAL – 6/30/2023**

**REDACTED**  
**ENTIRE PAGE CLAIMED**  
**CONFIDENTIAL – 6/30/2023**

**ATTACHMENT O**

**MONITORING, RECORDKEEPING,  
REPORTING, TESTING PLANS**



**ATTACHMENT O**

**MONITORING, RECORDKEEPING, REPORTING,  
AND TESTING PLANS**

TransGas Development Systems, LLC will work with the Division of Air Quality to identify and address Monitoring, Recordkeeping, Reporting, and Testing Plans. Requirements that are identified in the permit will be implemented.

**ATTACHMENT P**

**PUBLIC NOTICE**

# ATTACHMENT P

## AIR QUALITY PERMIT NOTICE

### Notice of Application

Notice is given that TransGas Development Systems, LLC has applied to the West Virginia Department of Environmental Protection, Division of Air Quality, for a Construction Permit for a Ammonia Production Facility located on Right Fork of Bens Creek Road near Wharncliffe in Mingo County, West Virginia. The latitude and longitude coordinates are: 37.615774 and -81.927364.

The applicant estimates the potential to discharge the following Regulated Air Pollutants will be: NO<sub>x</sub> of 63.05 tons per year (tpy), SO<sub>2</sub> of 0.03 tpy, CO of 21.47, tpy, VOC of 0.03 tpy, PM of 0.05 ty, PM<sub>10</sub> of 0.05 tpy, PM<sub>2.5</sub> of 0.05 tpy, CH<sub>4</sub> of 250.71 tppy, CO<sub>2</sub> of 1,650.41 tpy, and NH<sub>3</sub> of 5.27 tpy.

Startup of operations is planned to begin on or about the 1<sup>st</sup> day of September 2024. Written comments will be received by the West Virginia Department of Environmental Protection, Division of Air Quality, 601 57<sup>th</sup> Street, SE, Charleston, WV 25304, for at least 30 calendar days from the date of publication of this notice. Written comments will also be received via email at [DEPAirQualityPermitting@WV.gov](mailto:DEPAirQualityPermitting@WV.gov).

Any questions regarding this permit application should be directed to the DAQ at (304) 926-0499, Extension 41281, during normal business hours.

Dated this the **(Insert Date)** day of July, 2023.

By: TransGas Development Systems, LLC  
Adam Victor  
President  
630 First Avenue, Suite 30G  
New York, New York 10013-3799

**ATTACHMENT Q**

**BUSINESS CONFIDENTIAL CLAIMS**

## Cover Document Confidential Information

This sample form contains each of the required elements for the cover document required under 45CSR31. The person submitting this form may wish to attach an additional page(s) to provide adequate justification under the "Rationale" section of the form.

Company Name	TransGas Development Systems, LLC	Responsible Official	Adam Victor, President	
Company Address	630 First Avenue, Suite 30 G New York, NY 10016-3799	Confidential Information Designee in State of WV	Name	Patrick Ward
			Title	Senior Engineer
			Address	7012 MacCorkle Ave, SE Charleston, WV 25304
Person/Title Submitting Confidential Information	Adam Victor		Phone	(304) 342-1400
	President		Fax	(304) 343-9031

Reason for Submittal of Confidential Information: Initial permitting.

Identification of Confidential Information	Rationale for Confidential Claim	Confidential Treatment Time Period
All Marked Confidential Information.	<p>Provide justification that the criteria set forth in § 45CSR31-4.1.a - e have been met.</p> <p>The information contained within the application is fully protected under non-disclosure and confidentiality agreements by all parties involved in the application process and design of the facility.</p> <p>See Page Q2 of Q2.</p>	This information is to be maintained confidential. There is no timeframe for expiration of confidential treatment.

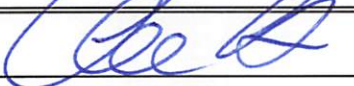
Responsible Official Signature:	
Responsible Official Title:	President
Date Signed:	6/30/23

**NOTE:** Must be signed and dated in **BLUE INK**.

**Provide justification that the criteria set forth in § 45CSR31-4.1.a - e have been met.**

4.1.a. The claim of confidentiality has not expired by its terms, nor been waived or withdrawn;

The confidentiality agreements do not have an expiration date due to the nature of the information contained in the application.

4.1.b. The person asserting the claim of confidentiality has satisfactorily shown that it has taken reasonable measures to protect the confidentiality of the information, and that it intends to continue to take such measures;

The information contained within the application is fully protected under non-disclosure and confidentiality agreements by all parties involved in the original development of the processes, the design of the facility, and the permit application process.

4.1.c. The information claimed confidential is not, and has not been, reasonably obtainable without the person's consent by other persons (other than governmental bodies) by use of legitimate means (other than discovery based on a showing of special need in a judicial or quasi-judicial proceeding);

The information available herein is not available and is not to be made available to outside parties.

4.1.d. No statute specifically requires disclosure of the information; and

Applicant believes there are no statutes that require disclosure of the information.

4.1.e. Either--

4.1.e.1. The person has satisfactorily shown that disclosure of the information is likely to cause substantial harm to the business's competitive position; or

This is a unique facility with many parties involved in preparing and providing information on the systems. Release of this information could cause substantial harm to Applicant's competitive position in the market.

4.1.e.2. The information is voluntarily submitted information, and its disclosure would likely to impair the State's ability to obtain necessary information in the future.

The State should not disclose this information to anyone.

# **APPENDIX 1**

## **CONFIDENTIAL HALDOR TOPSOE DOCUMENTS**

**REDACTED**  
**ENTIRE PAGE CLAIMED**  
**CONFIDENTIAL – 6/30/2023**



**REDACTED**  
**ENTIRE PAGE CLAIMED**  
**CONFIDENTIAL – 6/30/2023**

**REDACTED**  
**ENTIRE PAGE CLAIMED**  
**CONFIDENTIAL – 6/30/2023**

**REDACTED**  
**ENTIRE PAGE CLAIMED**  
**CONFIDENTIAL – 6/30/2023**

**REDACTED**  
**ENTIRE PAGE CLAIMED**  
**CONFIDENTIAL – 6/30/2023**

**REDACTED**  
**ENTIRE PAGE CLAIMED**  
**CONFIDENTIAL – 6/30/2023**

**REDACTED**  
**ENTIRE PAGE CLAIMED**  
**CONFIDENTIAL – 6/30/2023**

**REDACTED**  
**ENTIRE PAGE CLAIMED**  
**CONFIDENTIAL – 6/30/2023**

**REDACTED**  
**ENTIRE PAGE CLAIMED**  
**CONFIDENTIAL – 6/30/2023**



**REDACTED**  
**ENTIRE PAGE CLAIMED**  
**CONFIDENTIAL – 6/30/2023**

**REDACTED**  
**ENTIRE PAGE CLAIMED**  
**CONFIDENTIAL – 6/30/2023**

**REDACTED**  
**ENTIRE PAGE CLAIMED**  
**CONFIDENTIAL – 6/30/2023**

**REDACTED**  
**ENTIRE PAGE CLAIMED**  
**CONFIDENTIAL – 6/30/2023**

**REDACTED**  
**ENTIRE PAGE CLAIMED**  
**CONFIDENTIAL – 6/30/2023**

**REDACTED**  
**ENTIRE PAGE CLAIMED**  
**CONFIDENTIAL – 6/30/2023**

**REDACTED**  
**ENTIRE PAGE CLAIMED**  
**CONFIDENTIAL – 6/30/2023**

**REDACTED**  
**ENTIRE PAGE CLAIMED**  
**CONFIDENTIAL – 6/30/2023**



**REDACTED**  
**ENTIRE PAGE CLAIMED**  
**CONFIDENTIAL – 6/30/2023**

**REDACTED**  
**ENTIRE PAGE CLAIMED**  
**CONFIDENTIAL – 6/30/2023**

**REDACTED**  
**ENTIRE PAGE CLAIMED**  
**CONFIDENTIAL – 6/30/2023**

**REDACTED**  
**ENTIRE PAGE CLAIMED**  
**CONFIDENTIAL – 6/30/2023**

**REDACTED**  
**ENTIRE PAGE CLAIMED**  
**CONFIDENTIAL – 6/30/2023**

**REDACTED**  
**ENTIRE PAGE CLAIMED**  
**CONFIDENTIAL – 6/30/2023**

**REDACTED**  
**ENTIRE PAGE CLAIMED**  
**CONFIDENTIAL – 6/30/2023**

**REDACTED**  
**ENTIRE PAGE CLAIMED**  
**CONFIDENTIAL – 6/30/2023**



**REDACTED**  
**ENTIRE PAGE CLAIMED**  
**CONFIDENTIAL – 6/30/2023**

**REDACTED**  
**ENTIRE PAGE CLAIMED**  
**CONFIDENTIAL – 6/30/2023**

**REDACTED**  
**ENTIRE PAGE CLAIMED**  
**CONFIDENTIAL – 6/30/2023**

**REDACTED**  
**ENTIRE PAGE CLAIMED**  
**CONFIDENTIAL – 6/30/2023**

**REDACTED**  
**ENTIRE PAGE CLAIMED**  
**CONFIDENTIAL – 6/30/2023**

**REDACTED**  
**ENTIRE PAGE CLAIMED**  
**CONFIDENTIAL – 6/30/2023**

**REDACTED**  
**ENTIRE PAGE CLAIMED**  
**CONFIDENTIAL – 6/30/2023**

**REDACTED**  
**ENTIRE PAGE CLAIMED**  
**CONFIDENTIAL – 6/30/2023**



**REDACTED**  
**ENTIRE PAGE CLAIMED**  
**CONFIDENTIAL – 6/30/2023**

## **APPENDIX 2**

# **STARTUP AND EMERGENCY GENERATOR INFORMATION**



## Specification sheet

# Gaseous fuel generator set

1000 kW - 1300 kW  
60 Hz

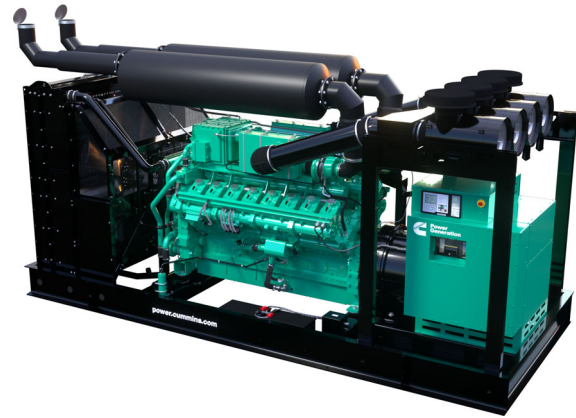

## Description

You can count on the 1000-1300 kW natural gas generator set (GenSet) for the reliability, quality, and dependability that is genuine Cummins performance. EPA-certified, this fully-integrated power generation system provides optimum performance and versatility for demand response and stationary standby power applications.

## Features

- Over 100 years of Cummins power generation technology and innovation
- Listed to UL 2200 and CSA standards for all low voltage models
- Stamford rugged and reliable alternator with state-of-the-art technology
- One-year (demand response) and two-year (standby) base warranty supported by a worldwide Cummins twenty-four hour, seven days-a-week, distributor network
- Accepts 100% rated load in a single step
- Capable of meeting NFPA 110 Type 10 for Level 1 emergency or standby power supply systems (EPSSs) when installed and operated per Cummins and NFPA guidelines
- Standard Power Command Control (PCC) 3300 technology provides digital (precise) frequency and voltage regulation
- Efficient and convenient operation monitoring and control options:
  - Modbus over the Internet (monitor and control)
  - Remote HMI (monitor and control)

Model	Power rating 60 Hz kW (kVa) Standby and demand response	Emissions	Data sheet
<b>C1000N6B</b>	1000 (1250)	EPA-certified for stationary emergency and non-emergency applications	NAD-C1000N6B
<b>C1300N6</b>	1300 (1625)		NAD-C1300N6

## Engine specifications

Base engine	Cummins QSK 60G
Displacement	3671 in <sup>3</sup> (60.1 L)
Minimum battery capacity	1800 amps at minimum ambient temperature of 0 °F (-18 °C)
Battery charging alternator	55 amps
Starting voltage	24-volt, negative ground
Standard cooling system	104 °F (40 °C)

## Alternator specifications

Design	Brushless, 4-pole, drip-proof revolving field
Stator	2/3 pitch
Rotor	Direct-coupled by flexible disc
Insulation system	Class H per NEMA MG1-1.65 or better
Standard temperature rise	125 °C
Exciter type	Permanent Magnet Generator (PMG)
Phase rotation	A (U), B (V), C (W)
Alternator cooling	Direct-drive centrifugal blower

## Outline drawing

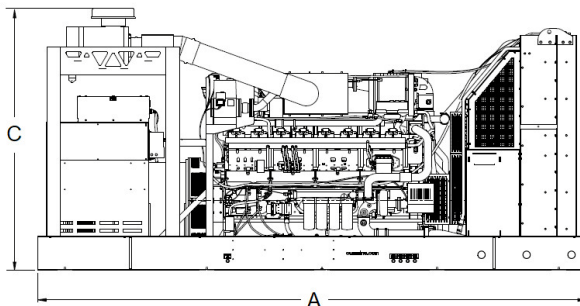
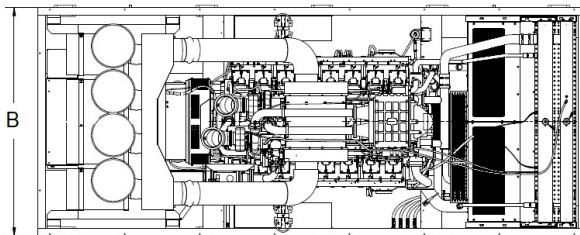

All models	Dim "A" in. (cm)	Dim "B" in. (cm)	Dim "C" in. (cm)
Open set	240 (610)	102 (259)	115 (292)
Sound-attenuated Level II enclosure	403 (1024)	102 (259)	128 (325)

*NOTE: Consult drawings for applicable weights. Contact the factory for additional information.*

This outline drawing is for reference only.  
**Do not use for installation design.**

## GenSet options and accessories

### Alternator

- 80 °C rise
- 105 °C rise
- 125 °C rise
- 120/240 V, 200 W anti-condensation heater

**Fuel system** - flexible fuel connector and fuel strainer

**Exhaust system** - critical grade silencer

### Generator set

- Batteries
- Battery charger - 120/208/240 V, 20A
- Main line circuit breaker
- Electronically-operated (E.O.) generator breaker
- PowerCommand Network I/O module
- PowerCommand Network Aux 101, 102 module
- Remote control HMI with extension harness
- Remote annunciator panel
- Spring isolators
- Audible alarm
- Sound-attenuated enclosure Level II with silencer
- Warranty - five-year standby including parts, labor, and travel

## Applicable codes and standards



The Underwriters Laboratory (UL) 2200 Listing is a comprehensive safety standard encompassing the design, construction, and performance of stationary GenSets.



CSA Group tests products under a formal process to ensure that they meet the safety and/or performance requirements of applicable standards. This GenSet is certified to: CSA 22.2 No. 100 Motors and Generators; CSA 22.2 No. 0.4-044 Bonding of Electrical Equipment; CSA 22.2 No. 14 Industrial Control Equipment; and CSA 22.2 No. 0 General Requirements - Canadian Electrical Code, Part II. All low voltage models are CSA-certified to product class 4215-01.



Engine is certified to Stationary Emergency and Non-Emergency U.S. EPA New Source Performance Standards (NSPS), 40 CFR 60 subpart JJJJ. U.S. applications must be applied per EPA regulations.

## ISO 9001:2015

This product has been manufactured under the controls established by an approved management system that conforms with ISO 9001:2015.

## PowerCommand 3.3 control system

An integrated microprocessor-based GenSet control system providing voltage regulation, engine protection, AmpSentry alternator protection, operator interface and isochronous governing.



### Advanced control methodology

- Designed for reliable operation in harsh environment.
- Provides battery monitoring and testing features and smart starting control system.
- Includes three-phase sensing, full wave rectified voltage regulation, with a PWM output for stable operation with all load types.
- Digitally governed with temperature dynamic governing and integrated digital electronic isochronous governing.
- **Prototype tested** - UL, CSA, and CE compliant.
- **Supports multiple languages**- English, Spanish, and French (standard); other languages, optional.
- **Protects the engine**- cranking lockout, overspeed shutdown, and battleshort; sensor failure indication; low fuel level warning or shutdown; low oil pressure warning and shutdown; high/low coolant temperature warning and shutdown; fail to start (overcrank) and fail to crank shutdown; and battery voltage monitoring, protection, and testing.
- **Enables paralleling control** - direct control of the paralleling breaker and displays breaker status; First Start Sensor System selects first GenSet to close to bus; Phase Lock Loop Synchronizer with voltage matching; sync check relay; isochronous kW and kVar load sharing; load govern control for utility paralleling; extended Paralleling (baseload/peak shave) Mode; and digital power transfer control, for use with a breaker pair to provide open transition, closed transition, ramping closed transition, peaking and base load functions.
- **Includes AmpSentry alternator protection** - over current and short circuit shutdown; over current warning; single and three-phase fault regulation; over and under voltage/frequency shutdown; overload warning with alarm contact; reverse power and reverse var shutdown; and field overload shutdown.
- Cummins InPower PC-based service tool connects to the PowerCommand 3.3 control system for detailed diagnostics, setup, data logging, and fault simulation.
- Comes standard with PCCNet and Modbus interface.
- Allows for up to twenty configurable data inputs and outputs.

### State-of-the-art operator panel

- Includes LED lamps indicating GenSet running, remote start, not in auto, common shutdown, common warning, manual run mode, auto mode and stop.
- **Displays engine data** - DC voltage and engine speed; lube oil pressure and temperature; coolant temperature; and comprehensive full authority electronic (FAE) data.
- **Provides GenSet data** - start attempts, starts, running hours, kW hours; load profile (operating hours at percent load in 5% increments); fault history – up to 32 events; data logging and fault simulation (requires InPower); air cleaner restriction indication; exhaust temperature in each cylinder.
- **Includes alternator data** - Line-to-neutral and line-to-line AC volts; three-phase AC current; frequency; kW, kVar, and power factor kVa (three-phase and total); and winding temperature and/or bearing temperature (optional).

Refer to document S-1570 for more detailed information.

# 100 YEARS OF **POWER** GENERATION

## **Ratings definitions**

### **Emergency Standby Power (ESP):**

Applicable for supplying power to varying electrical load for the duration of power interruption of a reliable utility source. Emergency Standby Power (ESP) is in accordance with ISO 8528. Fuel Stop power is in accordance with ISO 3046, AS 2789, DIN 6271, and BS 5514.

### **Prime Power (PRP):**

Applicable for supplying power to varying electrical load for unlimited hours. Prime Power (PRP) is in accordance with ISO 8528. Ten percent overload capability is available in accordance with ISO 3046, AS 2789, DIN 6271, and BS 5514.

### **Base Load (Continuous) Power (COP):**

Applicable for supplying power continuously to a constant electrical load for unlimited hours. Continuous Power (COP) is in accordance with ISO 8528, ISO 3046, AS 2789, DIN 6271, and BS 5514.

### **Demand Response Power Rating - Spark Ignited Gas (DRP):**

Applicable for supplying electrical power in parallel with commercially available power in variable and non-variable load applications. This fuel rating is intended for use in situations where power outages are contracted, such as in utility power curtailment. Engine operation is limited to a total of 500 hours per year. Engines may be operated in parallel to the public utility for up to 500 hours per year, with an average load factor no greater than 80% of rated Demand Response Power. Engines with Standby Power ratings available can be run in Emergency Standby applications up to the Standby Power rating for up to 50 hours per year. The customer should be aware, however, that the life of any engine will be reduced by constant high load operation.

**Warning:** Backfeed to a utility system can cause electrocution and/or property damage. Do not connect GenSets to any building electrical system except through an approved device or after the building main disconnect is open. Neutral connection must be bonded in accordance with National Electrical Code.

Specifications are subject to change without notice.

## **Power You Can Rely On**

To order, contact [centralregionorders@cummins.com](mailto:centralregionorders@cummins.com).  
Visit [cummins.com](http://cummins.com) to view all your power solutions.



Cummins Inc.  
Box 3005  
Columbus, IN 47202-3005  
U.S.A.

1-800-CUMMINS™ (1-800-286-6467)  
[cummins.com](http://cummins.com)

Printed in U.S.A.  
©2022 Cummins Inc.

**Generator Set Data Sheet**  
**1000 kW Standby Power**



**Model:** C1000N6  
**Frequency:** 60 Hz  
**Fuel Type:** Pipeline Natural Gas  
**Emissions NOx:** EPA NSPS & Non-Road Mobile Factory Certified  
**LT water inlet temp:** 50°C (122°F)  
**HT water outlet temp:** 90°C (194°F)

<b>Measured sound performance data sheet:</b>	<b>MSP-1089</b>
<b>Prototype test summary data:</b>	<b>PTS-640</b>
<b>Remote radiator cooling outline:</b>	<b>0500-5090</b>

<b>Fuel Consumption (ISO3046/1)</b>	<b>See Note</b>	<b>100% of Rated Load</b>	<b>90% of Rated Load</b>	<b>75% of Rated Load</b>	<b>50% of Rated Load</b>
Fuel Consumption (LHV) ISO3046/1, kW (MMBTU/hr)	2,3,5	2885 (9.85)	2630 (8.98)	2248 (7.68)	Below Minimum
Electrical Efficiency ISO3046/1, percent	2,5,10	36.4%	35.9%	35.0%	Tested
Thermal Efficiency ISO3046/1, percent	2,5,17	52.4%	52.6%	53.0%	Power

**Engine**

Engine Manufacturer	Cummins
Engine Model	QSK60G
Configuration	V16
Displacement, L (cu.in)	60 (3672)
Aspiration	Turbocharged and Charge Air Aftercooled
Gross Engine Power Output, kWm (hp)	1082 (1451)
BMEP, bar (psi)	12.3 (178)
Bore, mm (in)	159 (6.25)
Stroke, mm (in)	190 (7.48)
Rated Speed, rpm	1800
Piston Speed, m/s (ft/min)	11.4 (2244)
Compression Ratio	11.4:1
Lube Oil Capacity, L (qt)	379 (400)
Full Load Lubricating oil consumption, g/kWe-hr (g/hp-hr)	0.15 (0.11)

**Fuel**

Gas supply pressure to FSOV inlet, bar (psi) <sup>18</sup>	0.2 - 0.46 (2.9 - 6.7)
Minimum Methane Index	55



## Starting System(s)

Electric Starter Voltage, volts	24
Minimum Battery Capacity @ 40°C (104°F), AH	450

## Genset dimensions (see Note 1)

Genset Length, m (ft)	5.00 (16.40)
Genset Width, m (ft)	2.33 (7.64)
Genset Height, m (ft)	2.97 (9.74)
Genset Weight (wet), kg (lbs)	13924 (30697)

## Energy data

	See Notes	100% of Rated Load	90% of Rated Load	75% of Rated Load	50% of Rated Load
Continuous Generator Electrical Output kWe @ 1.0 pf	2,5,10	1050	945	787.5	Below Minimum Tested Power
Total Heat Rejected in LT Circuit, kW (MMBTU/h)	14	85 (0.29)	80 (0.27)	73 (0.25)	--
Total Heat Rejected in HT Circuit, kW (MMBTU/h)	14	719 (2.45)	653 (2.23)	556 (1.90)	--
Unburnt, kW (MMBTU/h)	14	93 (0.32)	86 (0.29)	75 (0.25)	--
Heat Radiated to Ambient, kW (MMBTU/h)	14	126 (0.43)	115 (0.39)	97 (0.33)	--
Available Exhaust heat to 120°C, kW (MMBTU/h)	14	795 (2.71)	731 (2.49)	635 (2.17)	--

## Intake air flow

Intake Air Flow Mass, kg/s (lb/hr)	14	1.83 (14513)	1.67 (13241)	1.43 (11345)	--
Intake Air Flow Volume, m³/s @ 0°C (scfm)	14	1.41 (3150)	1.29 (2880)	1.11 (2480)	--
Maximum Air Cleaner Restriction, mmHG (in H <sub>2</sub> O)	19	18.3 (9.8)	18.3 (9.8)	18.3 (9.8)	--

## Exhaust air flow

Exhaust Gas Flow Mass, kg/s (lb/hr)	14	1.89 (15038)	1.73 (13721)	1.48 (11759)	--
Exhaust Gas Flow Volume, m³/s (cfm)	14	4.15 (8790)	3.82 (8090)	3.32 (7030)	' -
Exhaust Temperature After Turbine, °C (°F)	4	500 (932)	507 (945)	518 (964)	--
Max Exhaust System Back Pressure, mmHG (in H <sub>2</sub> O)	12	37.3 (20.0)	37.3 (20.0)	37.3 (20.0)	--
Min Exhaust System Back Pressure, mmHG (in H <sub>2</sub> O)	12	0.0 (0.0)	0.0 (0.0)	0.0 (0.0)	--

## HT cooling circuit

HT Circuit Engine Coolant Volume, L (gal)		182 (48)	182 (48)	182 (48)	--
HT Coolant Flow @ Max Ext Restriction, m³/h (gal/min)	13,15	83 (365)	83 (365)	83 (365)	--
Maximum HT Engine Coolant Inlet Temp, °C (°F)	6	81 (179)	82 (180)	83 (182)	--
HT Coolant Outlet Temp, °C (°F)	6	90 (194)	90 (194)	90 (194)	--
Max Pressure Drop in External HT Circuit, bar (psig)	15	1.5 (21.8)	1.5 (21.8)	1.5 (21.8)	--
HT Circuit Maximum Pressure, bar (psig)		4.5 (65)	4.5 (65)	4.5 (65)	--
Minimum Static Head - Pump Inlet, bar (psig)		0.5 (7)	0.5 (7)	0.5 (7)	--

<b>LT Cooling Circuit</b>	<b>See Notes</b>	<b>100% of Rated Load</b>	<b>90% of Rated Load</b>	<b>75% of Rated Load</b>	<b>50% of Rated Load</b>
LT Circuit Engine Coolant Volume, L (gal)		34 (9)	34 (9)	34 (9)	--
LT Coolant Flow @ Max Ext Restriction, m <sup>3</sup> /h (gal/min)	13,15	23 (101)	23 (101)	23 (101)	--
Maximum LT Engine Coolant Inlet Temp, °C (°F)	7	50 (122)	50 (32)	50 (32)	--
Nominal LT Coolant Outlet Temp, °C (°F)	7	54 (129)	54 (32)	54 (32)	--
Max Pressure Drop in External LT Circuit, bar (psig)	15	1.0 (14.5)	1.0 (14.5)	1.0 (14.5)	--
LT Circuit Maximum Pressure, bar (psig)		4.5 (65)	4.5 (65)	4.5 (65)	--
Minimum Static Head - Pump Inlet, bar (psig)		0.5 (7)	0.5 (7)	0.5 (7)	--

### Emissions

NO <sub>x</sub> Emissions dry, ppm		<b>This rating is EPA NSPS Certified. Please refer to EPA emissions datasheet for regulation limits.</b>
NO <sub>x</sub> Emissions, mg/Nm <sup>3</sup> @5% O <sub>2</sub> (g/hp-h)		
THC Emissions wet, ppm	11	
THC Emissions, mg/Nm <sup>3</sup> @5% O <sub>2</sub> (g/hp-h)	11	
CO Emissions dry, ppm	14	
CO Emissions, mg/Nm <sup>3</sup> @5% O <sub>2</sub> (g/hp-h)	14	
CO <sub>2</sub> Emissions dry, percent	14	
CO <sub>2</sub> Emissions, mg/Nm <sup>3</sup> @5% O <sub>2</sub> (g/hp-h)	14	
O <sub>2</sub> Emissions dry, percent	14	
Particulates PM <sub>10</sub> , g/hp-h	14	

## Genset De-rating

### Altitude and Temperature Derate Multiplication Factor - On Grid, Soft Start

Barometer		Altitude		Table A									
In Hg	mbar	Feet	Meters	Derate Multiplier									
20.7	701	9843	3000	0.90	0.89	0.87	0.85	0.83	0.80	0.76	0.72	0.69	
21.4	723	9022	2750	0.94	0.93	0.91	0.89	0.88	0.84	0.80	0.77	0.73	
22.1	747	8202	2500	0.99	0.97	0.95	0.93	0.92	0.88	0.84	0.81	0.77	
22.8	771	7382	2250	1.00	1.00	0.99	0.98	0.96	0.92	0.88	0.85	0.81	
23.5	795	6562	2000	1.00	1.00	1.00	1.00	1.00	0.96	0.93	0.89	0.85	
24.3	820	5741	1750	1.00	1.00	1.00	1.00	1.00	1.00	0.97	0.93	0.89	
25.0	846	4921	1500	1.00	1.00	1.00	1.00	1.00	1.00	1.00	0.97	0.94	
25.8	872	4101	1250	1.00	1.00	1.00	1.00	1.00	1.00	1.00	1.00	0.98	
26.6	899	3281	1000	1.00	1.00	1.00	1.00	1.00	1.00	1.00	1.00	1.00	
27.4	926	2461	750	1.00	1.00	1.00	1.00	1.00	1.00	1.00	1.00	1.00	
28.3	954	1640	500	1.00	1.00	1.00	1.00	1.00	1.00	1.00	1.00	1.00	
29.1	983	820	250	1.00	1.00	1.00	1.00	1.00	1.00	1.00	1.00	1.00	
29.5	995	492	150	1.00	1.00	1.00	1.00	1.00	1.00	1.00	1.00	1.00	
30.0	1012	0	0	1.00	1.00	1.00	1.00	1.00	1.00	1.00	1.00	1.00	
				°C	20	25	30	35	40	45	50	55	60
				°F	68	77	86	95	104	113	122	131	140
<b>Air Filter Inlet Temperature</b>													

### Altitude and Temperature Derate Multiplication Factor - Off Grid

Barometer		Altitude		Table A									
In Hg	mbar	Feet	Meters	Derate Multiplier									
20.7	701	9843	3000	0.88	0.86	0.85	0.83	0.81	0.77	0.73	0.68	-	
21.4	723	9022	2750	0.92	0.91	0.89	0.87	0.85	0.81	0.77	0.72	0.68	
22.1	747	8202	2500	0.96	0.95	0.93	0.91	0.89	0.85	0.81	0.77	0.72	
22.8	771	7382	2250	1.00	0.99	0.97	0.95	0.94	0.89	0.85	0.81	0.77	
23.5	795	6562	2000	1.00	1.00	1.00	0.99	0.98	0.93	0.89	0.85	0.81	
24.3	820	5741	1750	1.00	1.00	1.00	1.00	1.00	0.98	0.93	0.89	0.85	
25.0	846	4921	1500	1.00	1.00	1.00	1.00	1.00	1.00	0.97	0.93	0.89	
25.8	872	4101	1250	1.00	1.00	1.00	1.00	1.00	1.00	1.00	0.97	0.93	
26.6	899	3281	1000	1.00	1.00	1.00	1.00	1.00	1.00	1.00	1.00	0.97	
27.4	926	2461	750	1.00	1.00	1.00	1.00	1.00	1.00	1.00	1.00	1.00	
28.3	954	1640	500	1.00	1.00	1.00	1.00	1.00	1.00	1.00	1.00	1.00	
29.1	983	820	250	1.00	1.00	1.00	1.00	1.00	1.00	1.00	1.00	1.00	
29.5	995	492	150	1.00	1.00	1.00	1.00	1.00	1.00	1.00	1.00	1.00	
30.0	1012	0	0	1.00	1.00	1.00	1.00	1.00	1.00	1.00	1.00	1.00	
				°C	20	25	30	35	40	45	50	55	60
				°F	68	77	86	95	104	113	122	131	140
<b>Air Filter Inlet Temperature</b>													

#### Temperature & altitude derate

- Determine derate multiplier vs. temperature and altitude in Table A.
- Assumes the LT return temperature is 10 °C above the air filter inlet with a maximum LT temperature of 50 °C.
- If the LT temperature exceeds 50°C, consult factory for recommendations.
- Altitude is based upon SAE standard ambient pressure vs. altitude. For low barometric conditions add 150 m (500 ft) to site altitude.

## Genset De-rating

### Heat Rejection Factor (altitude and ambient) for HT and LT Circuits

Barometer		Altitude		Table B									
In Hg	mbar	Feet	Meters	Multiplier for HT & LT (1/4) Heat Rejection vs Alt & Temp.									
20.7	701	9843	3000	1.11	1.13	1.14	1.15	1.17	1.18	1.19	1.20	1.22	
21.4	723	9022	2750	1.10	1.12	1.13	1.14	1.15	1.17	1.18	1.19	1.21	
22.1	747	8202	2500	1.09	1.10	1.12	1.13	1.14	1.16	1.17	1.18	1.20	
22.8	771	7382	2250	1.08	1.09	1.11	1.12	1.13	1.14	1.16	1.17	1.18	
23.5	795	6562	2000	1.07	1.08	1.09	1.11	1.12	1.13	1.15	1.16	1.17	
24.3	820	5741	1750	1.06	1.07	1.08	1.10	1.11	1.12	1.14	1.15	1.16	
25.0	846	4921	1500	1.05	1.06	1.07	1.09	1.10	1.11	1.12	1.14	1.15	
25.8	872	4101	1250	1.04	1.05	1.06	1.07	1.09	1.10	1.11	1.13	1.14	
26.6	899	3281	1000	1.02	1.04	1.05	1.06	1.08	1.09	1.10	1.12	1.13	
27.4	926	2461	750	1.01	1.03	1.04	1.05	1.07	1.08	1.09	1.10	1.12	
28.3	954	1640	500	1.00	1.02	1.03	1.04	1.05	1.07	1.08	1.09	1.11	
29.1	983	820	250	0.99	1.00	1.02	1.03	1.04	1.06	1.07	1.08	1.10	
29.5	995	492	150	0.99	1.00	1.01	1.03	1.04	1.05	1.06	1.08	1.09	
30.0	1012	0	0	0.98	0.99	1.01	1.02	1.03	1.05	1.06	1.07	1.08	
				°C	20	25	30	35	40	45	50	55	60
				°F	68	77	86	95	104	113	122	131	140
<b>Air Filter Inlet Temperature</b>													

#### LT & HT Circuit Heat Rejection Calculation

1. Determine derate multiplier vs. temperature and altitude in Table A.
2. Using the multiplier from #1 above as the percent load factor determine the heat rejection from the previous page.
3. From Table B find the LT circuit multiplier. \*The HT circuit multiplier is 1/4 of the multiplier shown in the table e.g. if the table says 1.04, the actual factor for HT is 1.01.
4. Multiply the result of step 2 by the result of step 3 to obtain the heat rejection at your altitude and temperature.

#### Methane Index Derate Multiplication Factor\*

Table C

#### Derate Multiplier

LT Inlet Temp		Derate Factor			
°F	°C	1.00	0.90	0.75	0.50
122	50	55	52	48	-
131	55	59	56	52	-
140	60	63	60	56	-
149	65	67	64	60	-
158	70	71	68	64	-

#### Methane Index Derate

1. Determine derate multiplier vs. Methane Number in Table C based on MN given your gas analysis input into the Cummins Gas Analysis Tool.
2. Using the multiplier from #1 above as the percent load factor determine the max load in kW using the nominal max rated load.

## Alternator Data

Voltage Range	Connection Configuration	Temp Rise Degrees C	Duty <sup>9</sup> Cycle	Winding No.	Alternator Data Sheet
380-480	Wye, 3 Phase	80	S	N/A	See Note 16
600	Wye, 3 Phase	80	S	N/A	See Note 16
4160	Wye, 3 Phase	80	S	N/A	See Note 16
12470-13800	Wye, 3 Phase	80	S	N/A	See Note 16
4160	Wye, 3 Phase	105	S	N/A	See Note 16
380-416	Wye, 3 Phase	125	S	N/A	See Note 16
440-480	Wye, 3 Phase	125	S	N/A	See Note 16

## Emergency Standby Power (ESP) Rating Definition

Applicable for supplying power to varying electrical load for the duration of power interruption of a reliable utility source. Emergency Standby Power (ESP) is in accordance with ISO 8528.

Note:

- 1) Weights and set dimensions represent a generator set with its standard features only. See outline drawing for other configurations.
- 2) At ISO3046 reference conditions, altitude 1013 mbar (30in Hg), air inlet temperature 25°C (77°F)
- 3) According to ISO 3046/l with fuel consumption tolerance of +5%, -0%
- 4) With air intake at 25°C (77°F). Tolerance ± 10°C.
- 5) Tested using pipeline natural gas with LHV of 35.64MJ/Nm<sup>3</sup> (905BTU/scf).
- 6) Outlet temperature controlled by thermostat. Inlet temperature for reference only. Data taken with 50% Glycol and with outlet temperature at max allowance.
- 7) Inlet temperature controlled by thermostat, outlet temperature for reference only. Data taken with 50% Glycol.
- 8) Without engine driven coolant pumps
- 9) Standby (S), Prime (P), Continuous (C)
- 10) At electrical output of 1.0 Power Factor, 97% Alternator Efficiency
- 11) Tolerance ±15%. Values shown are measured using fuel with less than 1% NMHC by volume. Values can vary significantly depending on NMHC found in the fuel.
- 12) Exhaust system back pressure is at rated load and will decrease at lower loads. Minimum restriction/back pressure is 0 mm H<sub>2</sub>O.
- 13) Flow including off engine thermostats.
- 14) Tolerance +/- 10%
- 15) Pressure drop external to genset.
- 16) Alternator model and data sheet information available on [www.powersuite.cummins.com](http://www.powersuite.cummins.com)
- 17) Exhaust gas cooled to 120 °C.
- 18) Fuel pressure capability will vary depending on fuel quality and site conditions.
- 19) Maximum Air Cleaner Restriction based on intake air temperature below 35 °C. If intake air temperature rises above 35 °C, contact Application Engineering for guidance.

For more information contact your local Cummins distributor  
or visit [power.cummins.com](http://power.cummins.com)

Our energy working for you.™



## **APPENDIX 3**

# **DETAILED PROCESS FLOW DIAGRAMS**

**REDACTED**  
**ENTIRE PAGE CLAIMED**  
**CONFIDENTIAL – 6/30/2023**

**REDACTED**  
**ENTIRE PAGE CLAIMED**  
**CONFIDENTIAL – 6/30/2023**



**REDACTED**  
**ENTIRE PAGE CLAIMED**  
**CONFIDENTIAL – 6/30/2023**

**REDACTED**  
**ENTIRE PAGE CLAIMED**  
**CONFIDENTIAL – 6/30/2023**

**REDACTED**  
**ENTIRE PAGE CLAIMED**  
**CONFIDENTIAL – 6/30/2023**

**REDACTED**  
**ENTIRE PAGE CLAIMED**  
**CONFIDENTIAL – 6/30/2023**

**REDACTED**  
**ENTIRE PAGE CLAIMED**  
**CONFIDENTIAL – 6/30/2023**

**REDACTED**  
**ENTIRE PAGE CLAIMED**  
**CONFIDENTIAL – 6/30/2023**

**REDACTED**  
**ENTIRE PAGE CLAIMED**  
**CONFIDENTIAL – 6/30/2023**

**REDACTED**  
**ENTIRE PAGE CLAIMED**  
**CONFIDENTIAL – 6/30/2023**